

THE OFFICIAL PUBLICATION OF ISA – INTERNATIONAL SOCIETY OF AUTOMATION

This Digital Edition of *InTech* magazine is brought to you by ISA – International Society of Automation and the advertisers who support this publication.

Identical to the print magazine that is available by mail six times per year, this Digital Edition is distributed to 42,000 registered subscribers located around the globe.

InTech advertisers support ISA and are pleased to provide additional information about their automation products and services. To obtain more information, first click the logos shown in the column on the right to see the ads in the magazine. Then, on the ad page itself, use the QR code or website address provided to get additional information.

**Register to subscribe to *InTech* Magazine
Digital Edition and don't miss a single issue**

REGISTER TO SUBSCRIBE



International Society of Automation
Setting the Standard for Automation™



InTech/Automation.com Media Planner



groups/137598

InternationalSocietyOfAutomation

ISA_Interchange

Richard T. Simpson
Account Executive
Email: richard@isa.org

Chris Nelson
Account Executive
Email: chris@isa.org

Gina DiFrancesco
Account Executive
Email: gina@isa.org

IntTech[®]

JUNE 2022



OFFICIAL PUBLICATION OF THE INTERNATIONAL SOCIETY OF AUTOMATION

www.isa.org/intech

VALVE STEM SEALING



Bridging On-Premise
and Cloud Data

Controls Programming for
Future Edge Computing

Micro VFDs Gain Macro Features

Flowmeter Tips to Improve Boiler
Efficiency

If it's in your panel, it's at AutomationDirect.com...for less!

Circuit protection including MCCBs, circuit breakers, and transfer switches
(Circuit breakers starting at \$15.00)

Wiring solutions including cut-to-length cable, hookup wire, wire duct, conduit, terminal blocks, and cable entry systems (Wire duct starting at \$7.50)

Drives, soft starters, and motor control devices
(Micro AC drives starting at \$128.00)

Enclosure lighting and thermal management
(Thermoelectric coolers starting at \$718.00)

Industrial power supplies, transformers, and converters
(DC power supplies starting at \$20.00)

PLCs, field I/O systems, motion controllers, servo and stepper systems (PLCs starting at \$85.00)

Industrial Ethernet switches, gateways, and VPN routers (Ethernet switches starting at \$83.00)

Safety products including safety controllers, safety relay modules, intrinsically safe isolators, etc. (Safety relays starting at \$103.00)

Modular and pre-fabricated enclosures
(Modular enclosure kits starting at \$875.00)

Plus motors, HMIs, pneumatics, a huge assortment of sensors and pilot devices, and so much more. All at great prices and with award-winning customer service and support.

Don't overspend elsewhere. With our everyday low prices you can build your panel for a lot less!

Research, price, buy at:

www.automationdirect.com



AUTOMATIONDIRECT.com
1-800-633-0405 the #1 value in automation



Monitor machine health with precise power data

New *groov* RIO EMU (energy monitoring unit)

- Monitor category III 3-phase AC power up to 600 V in Delta or Wye configurations
- Capture 18 data values per phase—voltage, current, true power, power factor, and frequency—plus 10 3-phase totals
- Measure power and energy at the point of use to detect downtime predictors like high power consumption
- Easily share real-time data with analytics software, databases, and dashboards using the built-in MQTT/Sparkplug client
- Secure the system and data with user accounts, configurable firewall, TLS certificates, HTTPS, and VPN client
- Quickly power for standalone operation with 802.3af PoE Class 0 switches or use 10-32 VDC line power



groov
RIO

Visit <https://op22.co/rioemu> to learn more!



Made and supported in the U.S.A.
Call us toll-free at 800-321-6786 or visit www.opto22.com
All registered names and trademarks copyright their respective owners.

OPTO 22
Your Edge in Automation.™

FEATURES

PROCESS AUTOMATION

12 Proper Valve Stem Sealing Best Practices

By Lisa Miller

Less leakage results in reduced product loss, increased efficiency, and improved energy management.

IIOT AND DIGITAL TRANSFORMATION

16 Bridging On-Premise and Cloud Data

By Megan Buntain

Hybrid data architectures empower process manufacturers to more quickly realize the business benefits from their cloud and IIoT investments.

FACTORY AUTOMATION

19 Future-Proofing Controls Programming for the Edge

By Darrell Halterman

Achieving traditional control while creating edge readiness.

OPERATIONS AND MAINTENANCE

24 Micro VFDs Gain Macro Features

By Kevin Kakascik

Compelling reasons to use newer and extremely capable micro VFDs.



Cover image courtesy of Emerson

DEPARTMENTS

6 Talk to Me

Global Collaborations Create Hybrid Events

By Renee Bassett

8 IIoT Insights

Implementing Rapid Roaming Technology

By Peter Szyszko

11 Executive Corner

FieldComm, OPC UA Collaboration Benefits Users

By Ted Masters

28 Automation Basics

Using Flowmeters to Improve Boiler Efficiency

By Scott A. Rouse

31 Association News

#AutomationProDay Winners, In Memoriam: Bridget Fitzpatrick, Widely Used ISA Symbols Standard Updated, Meet Graham Nasby, Return to In-Person Conferences, new CAPs and CCSTs, and more

34 Index of Advertisers

35 The Final Say

Optimize Energy Efficiency and Sustainability

By Bill Lydon

Secure Your Network

EDS-4000/G4000 Series Industrial Ethernet Switches

Futureproof Your Network Resilience

- IEC 62443-4-2 certified for enhanced security
- Features 90 Watts PoE and 2.5 GbE connectivity
- Modular power design for easier maintenance

Get Started

Have Questions?

USA@moxa.com



Global Collaborations Create Hybrid Events

By Renee Bassett, *InTech* Chief Editor



With so much disruption in supply chains, global trade, and workforce availability, manufacturers are forced to come up with new ways to attract, train, and retain employees.

To support industrial companies in their efforts to educate their automation, instrumentation, and IT employees, ISA has stepped up. ISA is collaborating with significant global partners to provide technical content and has added in-person conference components to its successful virtual-events programming.

ISA's first conference of 2022, held in March, included a collaboration with the Brazilian national oil company Petrobras. It was also ISA's first multilingual virtual event, as it featured a translation component with all presentations delivered in Portuguese with English closed captioning.

"The conference offered a wealth of digital transformation and cybersecurity content sessions developed and sponsored by Petrobras, followed the next day by ISA's IIoT & Smart Manufacturing virtual conference programmed by ISA staff and volunteer program committee," said manager of conferences and events Kimberly Belinsky. The agenda included a keynote by Indranil Sircar, Microsoft CTO for manufacturing and supply chain industry, as well as a panel of experts discussing how manufacturers are building organizational readiness for scaling up their smart factory projects.

The 2022 events program is highlighting the "international" aspect of the International Society of Automation through such partnerships and adding a welcome in-person component to virtual events. "We launched our virtual conferences in October 2020, and in 2021 attracted more than 12,000 global participants," said ISA senior manager of events Bill Furlow. "In 2022, we are

building on this success. These live events are being strategically supported around the world by ISA sections and local partners in specific regions."

The upcoming 2022 event schedule (<https://www.isa.org/events-and-conferences>) is as follows. Note that the locations shown indicate the time zones during which the virtual events will take place:

- Digital Transformation – India, 21 June. In-person location: Faridabad, Haryana, India. Supporting organizations: National Power Training Institute (NPTI) and Central Electricity Authority (CEA).
- Digital Transformation – North America, 30 August. In-person location: Houston, Texas. Local partner: ISA Houston Section.
- Digital Transformation – Asia, October date TBD. In-person location: Kuala Lumpur, Malaysia. Local partner: Petronas.
- Cybersecurity Standards Implementation – Middle East, 25 October. In-person location: Saudi Arabia. Local Partner: Saudi Aramco.
- Cybersecurity Standards Implementation – North America, 26 October. In-person location: Houston, Texas. Local partner: ISA Global Cybersecurity Alliance.
- ISA Annual Technical Conference covering process automation, digital transformation, cybersecurity, IIoT, and more – North America, 8–9 November. In-person location: Galveston, Texas.

ISA's hybrid conferences offer automation professionals powerful insights into key operational and business. All promise to help members of the automation industry develop the professional knowledge and digital skills needed to succeed. ■

EDITORIAL

CHIEF EDITOR

Renee Bassett, rbassett@isa.org

CONTRIBUTING EDITORS

Bill Lydon, blydon@isa.org

Charley Robinson, crobenson@isa.org

Jack Smith, jsmith@isa.org

STAFF WRITERS

Melissa Landon, Lynn DeRocco

ART & PRODUCTION

Lynne Franke, Production Editor

Bonnie Walker, Art Director

Jamie McLendon, Graphic Designer

Colleen Casper, Digital Designer

ADVERTISING & SPONSORSHIP

PUBLISHER

Rick Zabel, rzabel@isa.org

ACCOUNT EXECUTIVES

Richard T. Simpson, richard@isa.org

Chris Nelson, chris@isa.org

Gina DiFrancesco, gina@isa.org

MEDIA KIT

<https://tinyurl.com/InTechAcom2022mediakit>

ISA MEMBER LEADERS

ISA PRESIDENT

Carlos Mandolesi

PUBLICATIONS VICE PRESIDENT

Joao Miguel Bassa

PUBLICATIONS VICE PRESIDENT-ELECT

Nicholas Sands

INTECH EDITORIAL ADVISORY BOARD

Joseph Alford, Joao Bassa, George Buckbee,

Eric Cosman, Acacio Costa, Vitor Finkel,

Dean Ford, Narasimha Himakuntala,

Russ Rhinehart, Nick Sands, David Spitzer,

Sandeep Vysyaraju, Steven Valdez



We understand you need insightful process information to help you run your plant efficiently.

MEASURED VALUE + ADDED VALUE

You make confident decisions backed by process data and a complete portfolio of services and solutions to support you.

100%

of **Reference Standards** traceable to Nationally Recognized Standards.

Ensure compliance and increase process uptime with optimized services

- Lab and field accredited calibrations (A2LA) and verification capabilities for flow, pressure and temperature instruments
- Patented, industry-expert methods to optimize your calibration plan
- We are a leading manufacturer of process instrumentation – uniquely qualified to verify and calibrate
- Our global, harmonized calibration standards provide consistent service quality

Do you want to learn more?
www.us.endress.com/calibration-usa

Endress+Hauser 

People for Process Automation

Implementing Rapid Roaming Technology

By Peter Szyszko

Modern factories heavily rely on artificial intelligence-driven processes to optimize every step of production and also on precise data collected by numerous sensors. Historically, factories used slow, cable-driven serial protocols, for example, RS-232 cables or twisted pairs for RS-422/485. With the development of new technologies, there has been a transition to Ethernet-based communication. Two main factors play a key role in this process. The price of Ethernet nodes went down with the arrival of cheap microcontrollers that include fully integrated Ethernet communication hardware in one chipset, and the sophisticated sensors that provide the flow of data are not compatible with old serial buses.

Wi-Fi communication (wireless Ethernet) is a key technology for delivering all the necessary metrics from sensors. It provides freedom from cables, allowing unrestricted three-dimensional movement. Typical 802.11ac wireless

communication extends to 100 m. Commonly, this distance is not sufficient, and multiple access points (APs) are installed to cover a large operational area. In a scenario of moving wireless, the client (vehicle or robot) needs to switch over communication to the next strong signal AP. The best solution is the implementation of 802.11r across the infrastructure. It manages the switch-over mechanism with transitions of less than 50 ms. In some places, existing Wi-Fi infrastructure does not support 802.11r, but the need for moving installation demands fast transition times.

In this situation, one answer is an enhanced Wi-Fi client that can actively monitor surroundings and prepare new possible AP connection opportunities before classic die-down and drop-off connection processes take place, which cause a drop in communication for a minute or longer. Rapid roaming takes an active approach and seeks a new AP when communication is still healthy. It

ensures good throughput and fast transitions with a switch time less than 150 ms.

IEEE 802.11r wireless roaming

Roaming has been a desired feature in wireless devices for decades, and in 2002, the IEEE 802.11r standard was introduced. It is still under heavy development with major fundamentals published in IEEE 802.11r-2008. The main goal of 802.11r was to hand over wireless connections between numerous APs along a client travel path without significant delay. It has been particularly important for voice over Internet Protocol (VoIP) applications where human conversation requires transmission times of 50 ms or better to avoid noticeable interruptions.

The new 802.11r standard allowed speed with secure and seamless handoffs where authentication and quality of service (QoS) configurations were preconfigured ahead of switching to the next AP. It allowed a stable data throughput without delays caused by the regular authentication process (figure 1).

Fast roaming steps

- Authentication and QoS: In this step, two technologies are properly transitioning. Not only devices are connected to one AP, but the AP has the same privileges in respect to

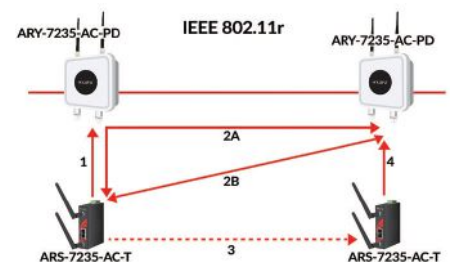

Figure 1. The 802.11r standard allows speed with secure and seamless handoffs, where authentication and QoS configurations are preconfigured before switching to the next AP. This allows stable data throughput without delays caused by the regular authentication process.

Rapid Roaming Application

An example of a place where this scenario has played out is in a warehouse application with autonomous robots. The robots move about the warehouse stocking shelves and fulfilling orders. Here, a legacy Wi-Fi network was already in place to support employees connecting their PCs, tablets, and phones, but the network did not have the necessary equipment to support 802.11r. The solution was fitting each of the robots with a wireless router that could implement rapid roaming technology at a fraction of the cost of installing an entirely new wireless network (figure 3).

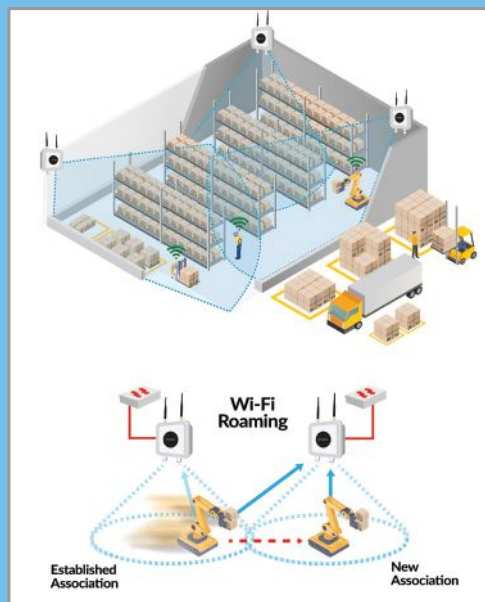

Figure 3. Fitting each robot with a wireless router enables rapid roaming technology.

DOES THIS MAKE SENSE?

Aliens travel faster than the speed of light but have not invented clothing



PROVEN
40
YEAR
BATTERY
OPERATING
LIFE*

DOES THIS MAKE SENSE?

Upstart battery manufacturers with little experience are claiming their products can last for decades. We've produced over 2.2 billion industrial grade lithium cells since 1975.



Don't use batteries that are alien to you.



* Tadiran LiSOCL2 batteries feature the lowest annual self-discharge rate of any competitive battery, less than 1% per year, enabling these batteries to operate over 40 years depending on device operating usage. However, this is not an expressed or implied warranty, as each application differs in terms of annual energy consumption and/or operating environment.

Tadiran Batteries
2001 Marcus Ave.
Suite 125E
Lake Success,
NY 11042
1-800-537-1368
516-621-4980

www.tadiranbat.com

communication priority. It is important for VoIP scenarios when delays could affect the human-to-human conversation.

- Exchange 802.11r (2a – cable, 2b – radio): This special protocol allows the exchange of all necessary information ahead of the travel path of a client, making the transition smooth and fast.
- Travel path: This is the way the client travels along the available APs. Fast roaming is particularly useful in

older installations when existing infrastructure does not support 802.11r. However, it is not as efficient as having 802.11r; it is attempting to close the gap with systems that do not have the roaming technology where conventional disconnecting and reconnecting occurs with new APs. This process may take a long time—sometimes even longer than a minute. It is frustrating when slow-moving clients operate with extremely weak AP signals when there is another AP with a strong signal level readily available in range (figure 2).



Figure 2. AP with a strong signal level available in range.

Requirements for the rapid roaming infrastructure include:

- Same service identifier (SSID)
- Same password
- Same security mode
- Same band
- Same channel width.

For the rapid roaming technology to work correctly, it is necessary to use an AP with the same SSID and security

key. When rapid roaming is enabled, the client device will be configured to scan for the surrounding APs. It is necessary to set slow scan time intervals to specify relatively slow scans when received signal strength indication (RSSI) signal levels are relatively high and the client device can comfortably concentrate on delivering the maximum data throughput. Then, it is necessary to specify the RSSI threshold level that indicates an imminent need for a new connection. When this level is reached, the client device will perform fast scans to look for a new AP. When it is detected, it will authenticate and auto-connect to the new AP while simultaneously dropping the current connection.

This active process eliminates weak signals deprived of links and prepares a new connection ahead when needed. In addition, there are two channel modes for scanning. One mode is “standard,” and it works when all the channels are scanned. The other mode is “intelligent,” and it works when a client device, for example, goes back and forth along the same APs. In this scenario, the device is smart and can learn those APs channels and look for them automatically. This further accelerates the reconnection process.

To implement 802.11r, the wireless infrastructure must support this standard. This typically requires significant additional investment, as most systems that support 802.11r must have a wireless local area network (LAN) controller in addition to the APs, which are then controlled by the wireless LAN controller. In applications where necessary infrastructure does not exist or where there are cost restrictions, rapid roaming technology can provide many of the same advantages at a much lower cost. ■

All images courtesy of Antaira Technologies



RTA
REAL TIME AUTOMATION
rtautomation.com | 800.249.1612

SIMPLY PUT...
WE MOVE YOUR DATA

Need to connect your OPC UA devices and integrate them into your industrial automation system?

We offer:

Industrial Protocol Gateways

- Connect your OPC UA Client to any protocol
- Seamlessly move your data throughout the factory floor across different technologies



OPC UA Server Source Code stack

- 100% ANSI C source code
- Easy to implement

Contact us today **1-800-249-1612** to learn more about which solution will work for you!



Member of **OPC FOUNDATION**



ABOUT THE AUTHOR

Peter Szyszko is director of engineering at Antaira Technologies.

FieldComm, OPC UA Collaboration Benefits Users

End users benefit when standards organizations collaborate—especially regarding architectures, networks, and protocols—to deliver improved ease of use, simpler integration, and backward compatibility. But before discussing collaboration benefits, definitions of leading terms are in order.

An “architecture” is a framework of information models and application and communication protocols that effectively specifies a complete system. For example, OPC UA is a platform-independent service-oriented architecture. Components of OPC UA are frequently used in automation systems.

A “network” refers to the physical hardware or layer, and the associated communication protocols (TCP, IP, UDP) used to transmit data via the hardware. Ethernet and Wi-Fi are familiar examples.

An application “protocol,” for example as defined by HART commands, is a software standard defining various aspects of communication over a network. In some cases, one standard defines both the communication and application protocols, as with *WirelessHART*.

Collaboration landscape

A primary example of collaboration between standards development groups is the long-standing partnership between FieldComm Group and the OPC Foundation. This relationship extends back to some of the earliest efforts toward creating device descriptions for instruments, and more recently, for the process automation device integration model (PA-DIM) and the field device integration (FDI) standards.

In 2017, FieldComm Group began working collaboratively on a new information model exclusively for devices typically used in process automation. Hosted by FieldComm Group, the first release of the PA-DIM specification was in June 2020. The members of the PA-DIM working group are currently developing a new release of the specification to include additional device types. OPC UA technology helps define the bits and bytes of clients and servers that support PA-DIM.

Another collaborator played a key role in the creation of PA-DIM, as its user requirements were defined by NAMUR as part of its open architecture model. This is one of the first technologies

designed from the bottom up for machine-to-machine communications between digitally transformed systems using semantic IDs.

The FDI standard is another example of collaboration to benefit end users. FDI provides a common approach for managing the integration of information associated with intelligent field devices to higher-level asset management and automation control systems for configuration, commissioning, diagnostics, calibration, etc.

FDI—including its specifications, tools, and registration procedures—is jointly owned by FieldComm Group and PROFIBUS & PROFINET International (PI). The OPC Foundation is a co-owner of the FDI specification with FieldComm Group, and the OPC UA Information Model for Devices specification is used within the FDI Server host component of the specification. The FDT Group is the final collaborator on FDI. All these organizations have a stake in promoting use of the technology with their specific automation networks and protocols standards.

FDI was designed for openness, including new automation protocols and incorporating innovative technologies. EtherNet/IP, ISA100 Wireless, and Modbus TCP are all supported within FDI technology, and in the past several years, FieldComm Group has collaborated with ODVA on several projects, one of which is FDI.

Users need a range of choices to realize the best price/performance ratio and ease of use.

FDI is a notable example, but not the only one, of how member organizations within an industry can collaborate on technology advancement while maintaining support for their unique offerings and installed base.

This type of collaboration and competition benefits end users, because no single architecture, network, or protocol standard is the best fit for every application. Users need a range of choices for the best price/performance ratio and ease of use. Collaboration among standards development organizations provides the required flexibility by supporting FDI across a wide range of architectures, networks, and protocols. ■



By Ted Masters

Masters, president and CEO of FieldComm Group, has supported the process industry in leadership roles at a wide variety of technology companies for more than 30 years. Masters has a BSEE degree from the University of Kentucky.

Proper Valve Stem Sealing Best Practices

By Lisa Miller

There are many methods of sealing valve stems on control and isolation valves. When chosen carefully, a valve stem seal provides years of reliable service, reduces environmental emissions, and minimizes product loss. When inappropriately applied, a valve stem seal can leak constantly, increase maintenance costs, create environmental issues, and place operating personnel at risk. The right valve stem seal

increases efficiency by minimizing product loss, which in turn reduces energy use, because less product needs to be made to satisfy demand.

Valve stem seals explained

Before delving into the details of selecting a valve sealing method, it is best to understand the challenges of sealing a valve stem and

Less leakage results in reduced product loss, increased efficiency, and improved energy management.



Figure 1. This control valve is subjected to EPA's Method 21 "sniff" test to determine the fugitive emission leak rate after a prescribed number of mechanical and thermal cycles.

explain how this might be done. Control and block valves fall into one of two major categories: sliding stem or rotary.

A sliding stem valve has a rod protruding from the body that rises and falls to open and close the valve. A rotary valve has a shaft extending out the side of the valve that is connected to a plug, disc, or ball. As the shaft turns, the rotary valve opens and closes. In either design, the valve stem must exit the body and be capable of relatively friction-free movement, while containing the process and preventing leaks.

The valve stem sealing assembly makes that possible. Sealing is usually accomplished in one of two ways: conventional packing or bellows seals. Details of how these methods work, along with pros and cons of each method, follows.

Measuring valve stem seal performance

Valve stem seals must accomplish two contradictory goals. First, they must seal the valve stem completely and reduce—and ideally eliminate—any fugitive emissions from the process. Second, they must accomplish this feat while allowing the valve stem to move freely and continue sealing, even as the valve stem cycles thousands of times. Several industrial standards address these requirements, but the required performance and test methods vary significantly.

The three main fugitive emissions standards are TA Luft, FCI 91-1, and ISO 15848. TA Luft is the least comprehensive of the three, offering leak rate standards based on gasket size and process temperature. However, it lacks specific test parameters for the number of test cycles required or the travel distance, so it is hard to compare the leakage results among different valve designs.

FCI 91-1 was created by the Fluid Control Institute and is more closely aligned with the leak detection and repair requirements mandated by the Environmental Protection Agency (EPA). It uses EPA's Method 21 to "sniff" the valve packing and determine the leak rate (figure 1). This standard provides details on how to test a valve. A valve stem seal design achieves various classification ratings based on the resulting leak rate after a specified number of mechanical and thermal cycles.

By far, the most comprehensive standard is ISO 15848. It has a variety of leakage classification rates for both control and isolation valves based on mechanical cycles, thermal cycles, and stem size. It also allows testing with either helium or methane, and it dictates two different ways to measure stem seal leakage for helium, each of which is much more involved than a simple sniff test. Specifically, the upperworks of the valve are encased in an airtight enclo-

sure and either flushed with a test gas or subjected to a full vacuum, while the inside of the valve is pressurized with helium. The amount of leakage can then be precisely measured.

When evaluating the performance of a valve stem seal arrangement, it is important to determine how the valve was tested and what specific classification it met. It is relatively easy to achieve very low leakage rates if the valve is mechanically cycled a small number of times. It is much more difficult to achieve and maintain very low leakage rates when the valve is mechanically cycled thousands of times, while enduring thermal cycles as well. The thermal cycles affect sealing due to the high expansion rate of PTFE (a synthetic fluoropolymer of tetrafluoroethylene, also known as Teflon) and the poor recovery rate of graphite, making packing design challenging.

Sealing valve stems with packing

The most common method of valve stem sealing employs a series of PTFE or graphite rings that encircle the valve shaft (figure 2 left). The rings are compressed with a combination of a packing follower, packing flange, and bolts to push down and squeeze the packing rings against the shaft. The compressed rings allow the valve stem to move while maintaining a seal against the valve body and shaft to keep process fluids from passing through the stem and escaping. In certain applications, the packing need only protect against gross process leaks, so relatively minor fugitive emissions are not a concern and free stem movement is considered a more important requirement.

To achieve and maintain low emissions, packing must be "live loaded" to keep constant pressure on the sealing rings (figure 2 right). This is usually accomplished using compressed Belleville-type springs. These springs maintain a constant force on the packing, ensuring it seals over time, even as the rings wear from stem movement. Unfortunately, the increased pressure tends to restrict valve movement, so

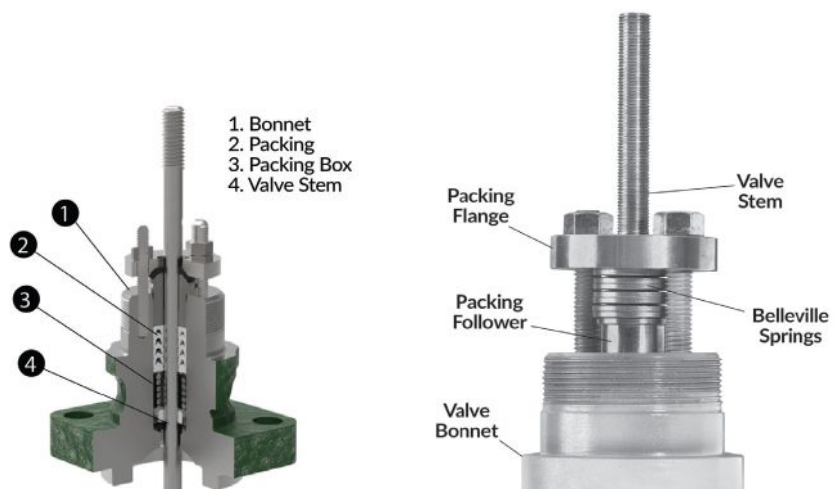

Figure 2. The picture on the left shows a typical rising stem control valve with standard packing. More modern packing designs, shown on the right, employ compressed Belleville-type or other special springs to maintain constant pressure on the packing rings. This ensures the fugitive emissions are limited to 100 ppm or less, even as the rings wear.

the sealing materials and valve stem finish must be carefully chosen to minimize fugitive emissions, while allowing valve stem movement.

Sealing valve stems with bellows

An alternative to valve packing is a valve bellows seal. A bellows seal uses a welded or mechanically formed metal barrier around the valve stem that can compress and stretch like an accordion (figure 3). Because the seal is made of metal with a very low rate of deformation in critical areas, bellows seals achieve virtually zero leakage.

Welded leaf bellow seals (figure 3 left and middle) are manufactured by welding together a stack of washer-like plates of thin metal to make a flexible seal with many folds over a given length. A formed bellows (figure 3 right) uses a flat sheet of metal formed and welded into a tube. The tube is then mechanically and hydraulically formed into a bellows.

Both designs can stretch about the same distance per fold, but because the formed bellows has far fewer folds per inch, its overall length is usually three times longer (figure 4). However, the reduced number of welds and corresponding mechanical stress allow formed bellows to last significantly longer in most applications.

Because bellow seals are constructed of relatively thin metal and subjected to mechanical stress and corrosion, they can crack and fail over time. For this reason, a bellows seal valve usually has a standard packing above it to contain the process should the bellows fail in operation.

Packing versus bellows

Each method of valve stem sealing has pros and cons, so the best choice depends on the application. Perhaps the biggest advantage of standard or environmental packing is its comparatively low cost, along with a wide variety of valve packing materials and designs to suit most applications. Valve packings can also be adjusted and replaced without disassembling the valve.

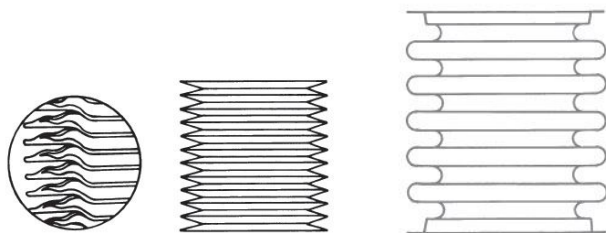

Figure 3. Bellows seal designs usually employ a welded leaf design (detail left and middle) or a mechanically formed design (right). A formed design can withstand many more cycles than a welded leaf design, but it is usually about three times longer.

The biggest advantage of a bellows design is its ability to deliver zero leakage. Such a specification is critical for lethal service applications. The bellow materials can also be chosen to handle higher temperatures and corrosive applications. Because the operational life of a bellows seal is based on the number and length of strokes, the estimated time to failure can be predicted with some accuracy, so replacement can be planned.

Each design has disadvantages as well. The performance and lifetime of packing is based on many variables, which are not always easily predicted. Small leaks usually can be addressed by tightening the packing, but at some point, the packing must be replaced. Also, the surface finish of the valve stem can have a big impact on the life and performance of a packing design. Regardless, all valve packing will leak to some extent, and this may not be acceptable in certain applications.

As mentioned previously, bellows seals will fatigue and eventually fail. When that occurs, the valve must be fully disassembled to replace the bellows seal. For this reason, the total cost of ownership for a bellows seal is typically higher than that of packing.

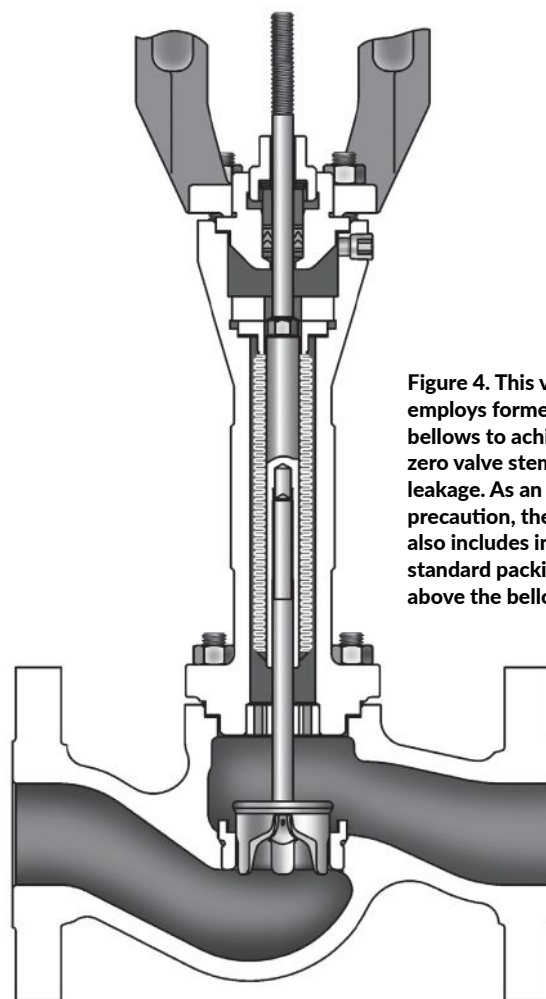

Figure 4. This valve employs formed bellows to achieve zero valve stem leakage. As an added precaution, the valve also includes integral standard packing above the bellows.

Application examples

When properly selected and applied, both packing and bellows seals can handle challenging applications. In one liquefied natural gas application in Australia, a 24-inch by 30-inch letdown valve used a specially designed environmental packing arrangement and had very low valve stem leakage, despite operating at cryogenic temperatures around -300°F (figure 5). Any fugitive emission from this valve translated into lost product, lost energy, and environmental damage—so it was critical to minimize leaks.

A Chinese chemical plant had a lethal service hydrogen cyanide application requiring virtually zero leakage while in operation, so a bellows seal design was selected. Upon commissioning, the plant reported zero measurable emissions, and after six years, still had no reported leakages. The valves went through 50,000 full cycles and more than 10,000 partial cycles annually.

Final thoughts

Proper selection of valve stem sealing is a critical component of the valve specification process. When chosen wisely, the design will perform reliably for the long term, translating into

significant reductions in environmental emissions, product losses, and maintenance costs. Losing less product improves efficiency and is a key component of energy management.

The number of design options are extensive, so end users may find it helpful to consult with their valve vendor to determine the best sealing design, materials of construction, and other details for their specific applications. ■

All figures courtesy of Emerson



ABOUT THE AUTHOR

Lisa Miller is a senior engineering manager for Fisher sliding stem valves at Emerson Automation Solutions. She has been the primary technical consultant for Fisher packing and bellows for more than 20 years, and she has 25 years of expertise with cryogenic valve design, testing, and manufacturing. Miller is the chairperson of the ISA75.27.01, Cryogenic and Low Temperature Seat Leakage Testing of Control Valves committee, and has been a member of ISA for 10 years. She has a BS in mechanical engineering from the University of Iowa.



Figure 5. This 24-inch by 30-inch letdown valve employs a specially designed large stem diameter environmental seal for extremely low leakage rates, as demonstrated here during a test at -56°F .



BRIDGING On-Premise and Cloud Data

By Megan Buntain

By 2028, cloud computing and the Internet of Things (IoT) in manufacturing will be poised to achieve the “plateau of productivity,” or the phase when they drive transformational impact on business outcomes, according to business analyst firm Gartner. At this point in their digital transformation journeys, many manufacturers

While the term “IIoT” was coined just a few years ago, the large volumes of data associated with it are familiar to the process control and automation industries. For decades, manufacturers have generated and collected more data than they know what to do with via sensors, legacy digital networks, and various host systems.

With the right hybrid architecture, manufacturers can analyze data in its native locations and formats, avoiding the complexities of data transfer or replication.

have completed their Industrial Internet of Things (IIoT) pilot projects and are approaching mid- to late-stage adoption in operations.

But a great deal of data was stranded in process historians and other databases, collecting dust. Today, manufacturers can

fully benefit from this data and information in the cloud by using hybrid data architectures coupled with advanced analytics applications.

Agile production and the IIoT

Transitioning to agile production requires optimizing the entire supply chain, from improving overall equipment effectiveness and asset reliability to reducing inventory. IIoT implementations can help organizations clear common optimization hurdles, because they empower staff to access, collect, and analyze more data in near real time. This enables process experts and operators to make timely and productive decisions to enhance product quality, optimize operations, and reduce waste.

With Internet connectivity, IIoT implementations can directly access the vast computing power and scalability of the cloud. Each year, the variability, speed, and volume of process data grows exponentially, rendering IIoT architectures as the only suitable options for compute-intensive Industry 4.0 projects.

Some of the leading cloud applications and components include digital twins, machine learning (ML) tools, autonomous robot artificial intelligence (AI) repositories, and augmented reality simulators. Each of these use cases requires high CPU processing power, which can be difficult for on-premise servers to provide because information technology (IT) teams cannot scale up the required computing resources on demand.

Cloud computing for manufacturing operations

According to Gartner, when it comes to cloud computing for manufacturing operations, the industry is currently in a “trough of disillusionment,” or a state of lowered expectations. This mindset is largely a result of the unproven idea that IIoT and related databases must feed a central data lake, which is intended to serve as the single source of truth and common access point for all users worldwide.

If this were true, cloud-based data lakes would need to replace all existing process historians—along with other host systems such as those used for asset management, laboratory information, or inventory tracking—to provide the data required for analysis. In reality, this is not the best approach because many legacy on-premise servers, such as those hosting process historians, collect and store highly valuable operational technology (OT) data. The context housed in these rich data archives is required to ensure Industry 4.0 initiatives, such as predictive maintenance via ML, succeed. Attempts to move or copy this OT data to the cloud are often time consuming and costly.

To properly aggregate and analyze the data produced by legacy sensors and infrastructure alongside new “born-in-the-cloud” IIoT sensor data, a bridge is required.

Hybrid approach to IIoT implementation

To address this issue and provide combined access to OT, IIoT, and other data, process manufacturers use a hybrid data architecture approach to:

- effectively leverage on-premise data, regardless of whether it is connected to the Internet
- take advantage of ML and advanced analytics opportunities by streaming select data to the cloud
- use the process domain expertise and skills of their existing workforce
- reduce in-house data acquisition, storage, access, and maintenance costs
- increase data availability
- integrate AI/ML into industrial processes.

This is not a rip-and-replace approach but is instead a bridge connecting traditional manufacturing data infrastructure with cloud-native data to leverage the best data from both sides by creating a continuum of access. Process automation systems can continue to use on-premise or edge data for real-time decision making where low latency is required. Simultaneously, the hybrid model empowers organizations to apply global reporting and compute-intensive tasks, like ML, to cloud-native IIoT data (figure 1).

This approach requires a data abstraction layer to facilitate traffic flow among various data sources (figure 2).

Data abstraction indexes and facilitates access to data in its native locations, a key differentiating point from data-lake functionality. Because data is not copied or moved, its management is significantly simplified. Once data abstraction is implemented, organizations can add advanced analytics applications to simultaneously query and make use of information from multiple, and often previously disparate, data sources. This improves awareness and predictive maintenance capabilities across the organization.

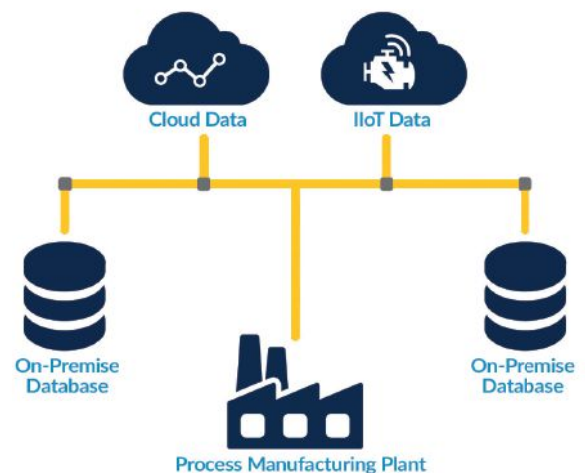

Figure 1. Hybrid data architectures empower manufacturing organizations to leverage IIoT in the cloud for compute-intensive processes, while executing real-time process control using on-premise data.

For example, when training and executing ML models, organizations must access maintenance records and historical process data. Staff must then access results to proactively identify issues and adjust the operational model. Abstraction makes it easy for personnel and software applications to access multiple datasets through a single source.

Hybrid data architecture for asset monitoring

Asset monitoring is a critical task for many process manufacturers. For common assets—including pumps, valves, heat exchangers, and others—manufacturers deploy a variety of maintenance methods to maximize productivity over the asset’s life. At the two extremes, these methods include “run to fail” in the most basic case, and condition monitoring for predictive maintenance in more advanced situations.

By monitoring asset performance to detect anomalies in near real time, manufacturers can identify potential issues before failure, reducing unplanned downtime and maintenance costs. When these anomalies are detected, advanced analytics software can generate alerts to inform personnel, so they can schedule inspections and maintenance of affected assets.

These monitoring applications can be scaled to hundreds of assets across multiple sites. Therefore, it is critical to normalize data before generating alerts and to streamline notification paths so the right personnel are informed.

By working together, OT and IT teams can use a hybrid data architecture to achieve these asset monitoring goals. First, OT teams must deploy suitable sensors, in addition to data acquisition and storage technologies, to populate asset hierarchies with data for grouping equipment and devices of a common process or location. These asset hierarchies include sets of metadata collected for each asset of a common

taxonomy. Once the hierarchies are in place, assets can be analyzed within process groups, rather than individually, or solely as unrelated assets of the same type.

Next, OT works with IT personnel to ensure the former group can access this data securely by implementing cloud data storage, advanced analytics, and workflow automation tools. IT and data science teams collaborate with OT subject matter experts to configure ML models that create insights and effectively predict asset failure, generating intelligent alerts to improve issue remediation and decrease downtime.

Consider hybrid data architecture

When evaluating hybrid data infrastructure, organizations should consider these questions before implementation:

- Does the software solution provide access to both OT and IIoT data sources simultaneously, for both querying and analysis?
- Can users generate dashboards and reports in near real time?
- Does the infrastructure provide on-premise OT data to the digital transformation team for use in Industry 4.0 applications, such as ML and digital twins?
- Is there significant cost and effort associated with implementing and maintaining the solution?
- Can the infrastructure support the organization’s current and future data architecture as it inevitably changes?

Hybrid data architectures empower process manufacturers to more quickly realize the business benefits from their cloud and IIoT investments. By using IIoT data and pipelines, on-premise process data, abstraction, and advanced analytics, organizations can quickly pass through the trough of disillusionment and reach the digitalization plateau of productivity. ■

All figures courtesy of Seeq

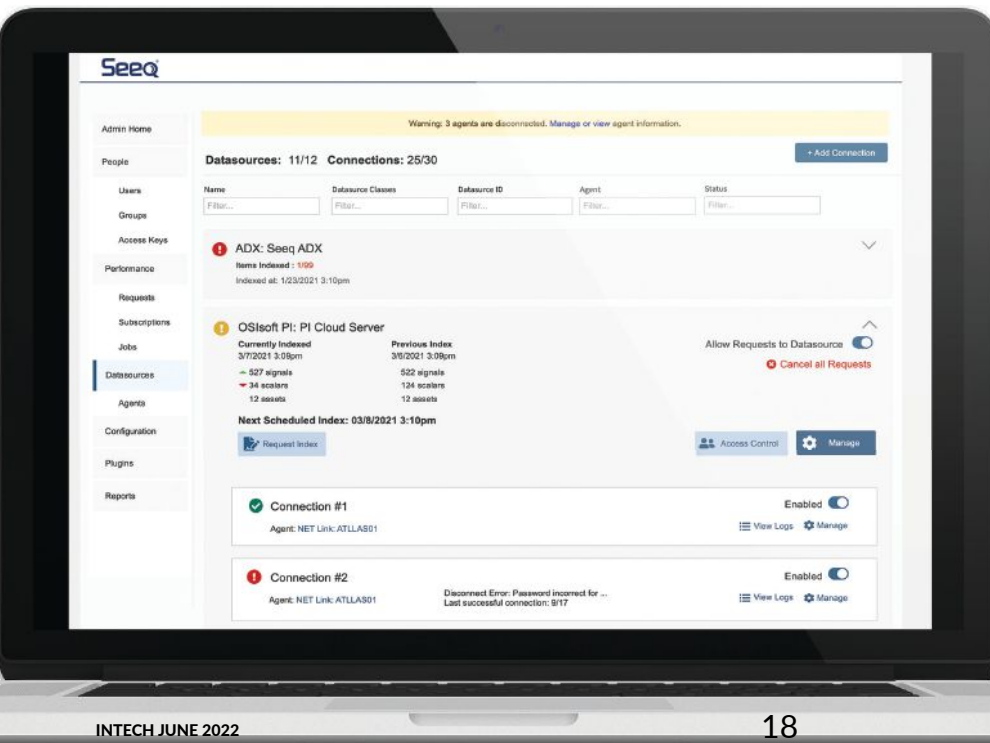



ABOUT THE AUTHOR

Megan Buntain is the director of cloud partnerships at Seeq Corporation, a company building advanced analytics applications for engineers and analysts that accelerate insights into industrial process data. She was formerly a consultant with analytics, IoT, and blockchain software and services companies, and prior to that worked at Microsoft for 15 years.

Figure 2. Data abstraction layers facilitate data access and transfer among multiple data sources, including on premise and cloud databases.

Future-Proofing Controls Programming for the Edge

Edge computing, new communication methods, and advanced analytics are among the hottest topics related to industrial automation, a field more often associated with stoic reliability than cutting-edge technology. Yet there remains a fundamental need for creating traditional deterministic control solutions suitable for new and retrofit automation projects.

Designers are often concerned about managing interactions with industrial automation devices, especially as hardware and communications capabilities rapidly evolve. Fortunately, by adopting some basic tools and strategies for abstracting application data, interactions with modern edge controllers can be nearly as easy as traditional programmable logic controllers (PLCs).

As hardwired relays yielded to PLCs, which in turn were surpassed by programmable automation controllers (PACs), the means and methods of programming control systems have adapted. The same evolution is occurring as edge controllers and other edge devices begin entering

service. Controls programming during the edge evolution does not have to mean wholesale change but can instead offer more choices.

By Darrell Halterman

Well-designed edge controllers remain highly compatible with existing PLC/PAC ecosystems. Embrace new strategies and tools to adapt and gain new capabilities.

The edge is here

Most users have heard terms like “edge computing” and “digital transformation,” but many may feel unsure how edge computing can solve

problems in their applications. At least, users stand to gain improved visibility into equipment and process operations, even via mobile devices. Streamlined data gathering capabilities support analytics at the edge and in the cloud, which provide novel insights for improving availability, utilization, and efficiency. In the most advanced scenarios, edge controllers can autonomously leverage analytical results to advise deterministic control applications for near-real-time responsiveness.

Even as these Industrial Internet of Things (IIoT) capabilities become more commonplace, not every developer or project is ready to commit to wholesale edge automation. By architecting a control solution properly, end users can implement classic functionality today, while future-proofing their designs to take advantage of the edge moving forward (figure 1).

Developers unfamiliar with edge controllers may feel compelled to stick with tried-and-true control technologies and products. But the immediate impacts of ongoing labor and component shortages demand modernized systems that counter these challenges by taking advantage of new ways of accessing and using data. Developers and end users can embrace making their automation designs IIoT ready, and rest assured the required programming will build on past concepts.

Programming evolution

When discrete automation operational technology (OT) originally shifted from hardwired systems created with electromechanical relay and timer devices to electronically programmable devices like PLCs, the Ladder Diagram (LD) language was created to help transition developers and technicians to the new solution. Visually, LD programming looks like the wiring diagrams used with hardwired relay and timer systems—but it greatly simplified programming, debugging, and modifying sequencing logic with a PLC.

As PLCs gained power and began to perform more complex functions like mathematics, analog loop control, and motion control, the associated languages had to evolve for performing complex expression processing, advanced process control, and motion. Languages like Structured Text (ST) arose to meet the new programming and debugging demands, yet LD was still available.



Figure 1. Edge controllers are a modern way to provide PLC/PAC functionality, while future-proofing designs and providing flexibility to enhance operations.

The development of PACs represented an expansion of PLC functionality to incorporate even more advanced application processing and communication functionality. PACs began to take on tasks we would associate with the edge today, although their dedicated real-time operating systems (RTOS) imposed some limitations. In many cases, users found it necessary to create complex algorithms, like machine learning strategies, using modern information technology (IT)-type languages like C++ and Python, running on PCs and industrial PCs (IPCs) working in conjunction with PACs.

Now edge controllers are on the scene, combining industrial-grade OT control with IT-type computing in one compact form factor tough enough to survive edge locations. Programming is evolving again.

Edge programming concepts

Some end users may opt to create edge solutions using a variety of hardware platforms and programming methods. This ad hoc approach introduces risk and requires time-consuming testing and integration efforts that generate late-stage changes and potential cost increases unacceptable in today's industrial projects.

Selecting hardware and software offered as part of a wide portfolio of coordinated industrial automation products from a single provider ensures compatibility. A compatible portfolio of PLCs, PACs, edge controllers, and the software they run makes it possible for users to learn just a few program-

ming tools and apply them to many products. Harmonized library objects lead to greater consistency and rapid development; proven code is readily reused on projects; and data is more readily transferred among systems.

To ensure future-proof solutions, users should look for product portfolios that embrace open programming, software, and communication standards wherever possible. Even open standards may benefit from industrial-centric extensions where appropriate. For an edge controller, this requires:

- deterministic control engines that support well-known and stable IEC-standard and C languages
- variable programming, with rich standard and user-defined data types
- extensive standard and user-defined function blocks
- support for object-oriented communications protocols like OPC UA that can seamlessly transmit data in context between deterministic and analytic applications
- support for OT-centric communication protocols like Modbus, Profibus, and Profinet
- Linux-based OS for the general-purpose computing part of the edge controller—bootable and upgradable independently of the deterministic control portion. Linux is lightweight and has high performance while using fewer CPU and RAM resources than other alternatives
- ability to run open-source apps like Node-RED and Grafana, as well as commercial and custom apps
- programmable using C/C++, Python, and other modern languages suitable for applications like machine learning and artificial intelligence
- support for IT-centric communication protocols like MQTT and HTTPS.

A true edge controller with these features is the best choice for implementing traditional deterministic control today and taking advantage of the edge computing evolution now and in the future.

Edge control and computing

Edge controllers are touted by many suppliers, but these devices vary significantly in performance and internal operation. For performance and security reasons, the most capable implementations use hardware virtualization to ensure the deterministic controller runs independently of the edge compute activities. Rigorous segregation of OT and IT environments is provided at hardware and software levels.

Today's controls designers may be hesitant to apply new edge controllers to equipment and systems usually automated with PLCs or PACs. They may be concerned about the skillset required to make an edge control solution work reliably. They may feel unsure of the benefits gained from trying a new architecture.

These reservations disappear if the deterministic portion of the edge controller runs the same kernel as PLCs and

PACs from the vendor and uses the same integrated development environment toolchain and toolchest of library functions. An edge controller can be used as a PLC or PAC today, even to the extent of using the same logic libraries developed for PLC/PAC members of the same product family. There is great power in using familiar methods tied to new capabilities to obtain new results.

If the edge compute portion of the edge controllers uses an open standard OS like Linux, users are free, in the future, to add almost any type of application needed. The immediate benefits are more compelling if the edge controller is available with a curated set of open source and commercial applications suiting the most common industrial computing needs (figure 2).

Control. The value of using an edge controller as a supercharged PLC/PAC is that the edge controller is natively ready to run visualization, data connectivity, analytical applications, and much more whenever the user is ready to take advantage of these functions. No additional hardware is needed; no cutovers or physical tie-ins are needed; and there is no requirement to interrupt execution of the automation application. Modern languages can be used where and when they are best suited for an application. End users gain the flexibility to extend their applications with edge capabilities when they are ready.

Computing. On the other hand, it is common for manufacturing facilities to have significant quantities of legacy automated equipment already in service. End users at these facilities may want to test the IIoT waters, but simply cannot jeopardize production.

In this case, using an edge controller only for the IT computing capabilities and OT connectivity, without even one line of control logic, is a practical approach. The edge controller can be installed anywhere on the factory floor, just like a PLC/PAC, and one edge controller can be networked to many PLCs/PACs, sensors, or other instruments to act as a gateway and information concentrator.

Operating in this capacity, users configure the edge controller to gather data, provide visualization hosting, and preprocess the data—such as filtering, averaging, or even executing local analytics—as needed, and to forward the information to higher level systems. Users can add and scale up this IIoT functionality at their own pace, without affecting any underlying automation systems.

Control and computing. Although the individual control and computing capabilities of edge controllers are important, users gain maximum advantage by combining them in support of one application. The deterministic “inner loop” directly accesses field-sourced data and controls devices. The edge compute “outer loop” combines deterministic data and real-time information from outside sources or analytics to advise the inner loop on operating parameters and tuning to achieve optimal efficiency (figure 3).

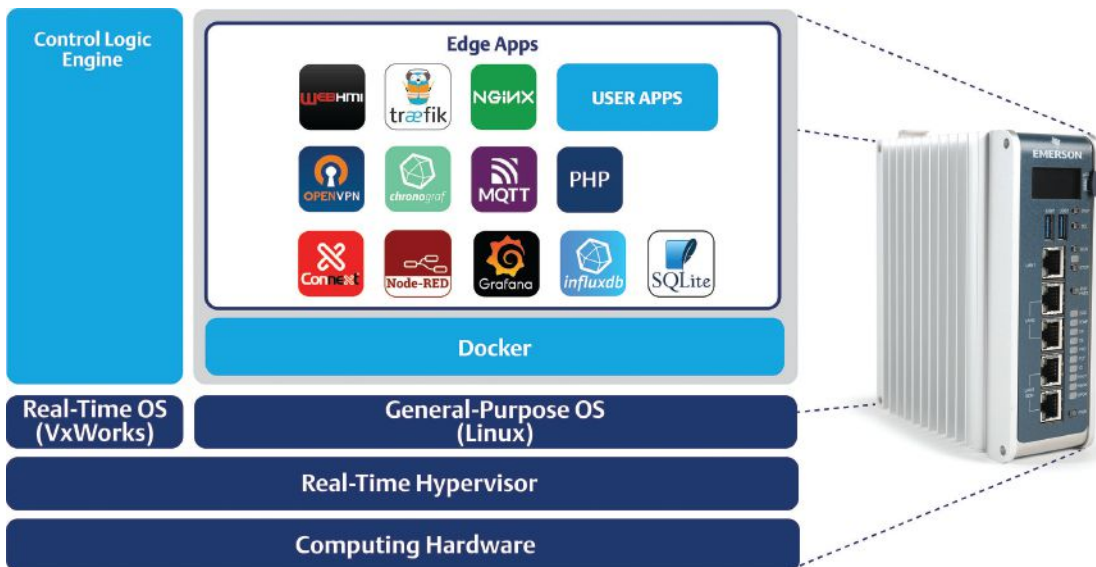

Figure 2. Some edge controllers use Linux for the edge computing platform, so they can run a wide variety of user applications. In addition, users can take advantage of preloaded industrial edge platform software, providing the apps needed to help manufacturers accelerate digital transformation projects.

Edge controller drone application

Exemplifying the new potential made available by edge controllers, an end user recently explored using commercial drones for inspecting remote pipeline. The user was able to quickly incorporate the standard Linux software development kit (SDK) for a popular commercial drone into the edge compute portion of the edge controller. Using standard OPC UA communications, the company activated the drone to fly predetermined inspection routes either on default time intervals or on alarm conditions as commanded by the deterministic control portion of the edge controller. The edge compute portion captured video and telemetry data and then posted it to a secure web dashboard for remote operators to assess in real time.

Looking ahead

Edge programming is more evolution than revolution. Originally, PLCs performed specific jobs and were programmed using correspondingly specialized methods. As PLCs improved and progressed to become PACs, the programming means and methods preserved the best aspects of the original Ladder Logic roots, but gained new languages, function blocks, and organizational methods as needed in support of added capabilities.

Edge controllers represent an exponential capability increase over traditional PLCs and PACs, so it makes sense that even more languages and applications are being added. This does not mean end users need to discard their experience or embrace all the added capabilities at once.

Instead, well-designed edge controllers remain highly compatible with existing PLC and PAC ecosystems, so users can continue to build on their OT knowledge base. When they are ready to extend applications into the IT realm, the same edge controller provides a general-purpose computing platform, effectively future-proofing their applications. ■

All figures courtesy of Emerson



ABOUT THE AUTHOR
Darrell Halterman is a director of PAC-Systems controls products at Emerson’s machine automation solutions business. He is also responsible for the portfolio’s control solutions modernization strategy.

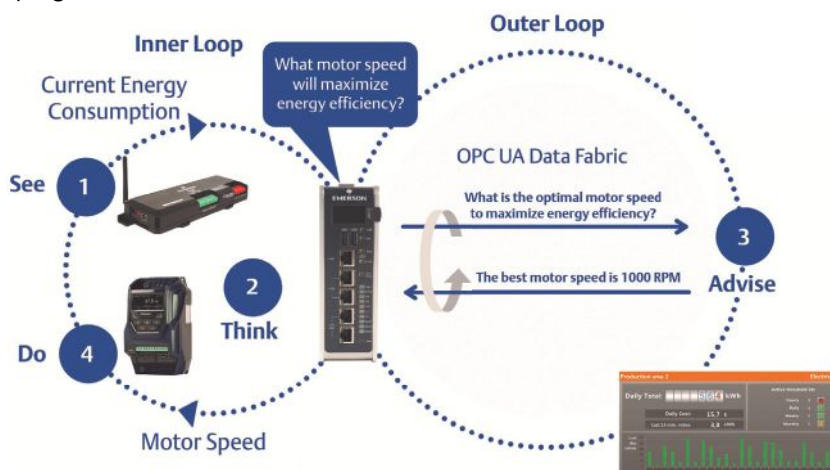

Figure 3. Edge controllers seamlessly combine OT and IT operations, using programming methods optimized for integrating each role.

The Plant Floor in Your Pocket

Get an overview of your process at a glance.
Control your SCADA with a swipe.



See the live demo now.
Scan this QR code with your phone
or visit demo.ia.io/tech





Micro VFDs Gain Macro Features

Figure 1. Many industrial applications and small machines with a motor and limited I/O requirements can benefit from using AC VFDs with an integrated PLC.

OEMs and hobbyists benefit from technology's trickle-down effect.

By Kevin Kakascik

We have witnessed the trickle-down effect of technology. From expensive luxury brand cars to the newest mobile phone each year, the top model almost always has exclusive features. However, frugal and patient consumers—as opposed to early adopters—will eventually see these same technologies become available on lower-cost products.

This fairly universal model spans many industries, among them industrial automation. AC variable frequency drive (VFD) users continue to benefit from new features formerly available only on flagship products.

VFD progress

Electric motor speed often needs to be controlled for applications involving machinery, pumps, and other equipment (figure 1). At one time, the only way to vary the speed of an electric motor—while maintaining full torque below base speed—was to use a DC motor and a DC drive. This was because the first AC VFDs only operated in V/Hz mode and lost torque proportionally with any decrease below their base speed. However, once the flux-vector AC VFD became available, 100 percent of the motor's torque could be produced across the entire speed range from zero to base speed.

Early flux-vector AC VFDs experienced several problems. Limited horsepower ranges were available; the units were large and kept in a room away from other equipment; and long cable lengths caused electrical issues. These were also expensive, custom-engineered drive systems.

Eventually, the trickle-down effect began to occur, and flux-vector VFDs were sold as packaged products that could work for many applications. Lower-cost VFDs remained available for basic applications needing only simple V/Hz control.

By the early 2000s, fewer custom-engineered systems drives were sold, and most were prepackaged but had impressive features in addition to supporting flux-vector control. Other popular features included advanced networking capabilities, safety features such as safe torque off, proportional-integral-derivative (PID) control, and even a built-in programmable logic controller (PLC) with expansive I/O options to allow for process or machine control in addition to motor control.

The least with the most

Just a few years ago, the lowest-cost VFDs on the market still only supported V/Hz control and were basic, with lower quality to remain affordable for original equipment manufacturers (OEMs) and hobbyists. Again, the trickle-down effect has taken place, and many higher-end features and improved build quality are found on lower-cost VFDs.

Today's entry-level VFDs, within the price range of OEMs and hobbyists, make project design and implementation much easier with features like:

- single-phase input to three-phase output
 - sensorless vector control for increased torque at lower speeds
 - advanced support for networks such as EtherNet/IP and Modbus TCP
 - PID control for process closed-loop control
 - an integrated PLC to perform logic, which in some applications eliminates the need for a separate PLC.
- These newly available features can benefit users in many ways.

Singe phase to three phase. A VFD with a single-phase input and a three-phase output is a “no-brainer” when comparing features for an OEM or hobbyist. Most hobbyists do not have three-phase power available in their shops or garages, but they may need to control a three-phase motor. For an OEM, this feature gives the option to design for a single-phase power connection and is likely to appeal to more customers, and not just those with three-phase power available.

Although a VFD is not a phase converter, it can convert 120 VAC or 230 VAC single-phase to a three-phase output for motor control. The benefits of

choosing a three-phase motor over a single-phase motor are too lengthy to list, but improved speed control is usually enough to convince users that a three-phase motor is the best choice.

Torque. Sensorless vector control allows users to reduce motor speed to very low speeds without losing torque. On a typical lower-cost VFD with only V/Hz control (also known as scalar control), the motor loses output torque proportionally to the reduction in speed. For example, a 0.5 hp motor with a base speed of 1,725 rpm and a full load torque rating of 1.5 lb-ft at 100 percent speed will only provide 1.0 lb-ft at 66 percent speed. With sensorless vector control technology, it is possible to produce 100 percent of the motor's torque output at very low speeds.

Before sensorless vector technology was available, designers could use a lower rpm motor of the same horsepower to achieve the lower fixed speed, or they could use a DC motor and drive. The former is not adjustable and often involves a larger frame size, which may require higher-cost mechanical changes. The latter is robust but calls for higher maintenance, such as changing brushes, and many smaller DC drives are analog and lower tech. They do not typically offer communications or fancier control options, at least at the same price point.

Networking. Advanced networking is a bonus for many reasons. Many VFDs—even going back to the very first ones available—supported some sort of serial communications but may have required specialized cables. Today, many VFDs commonly support Ethernet communications, so configuring the VFD is

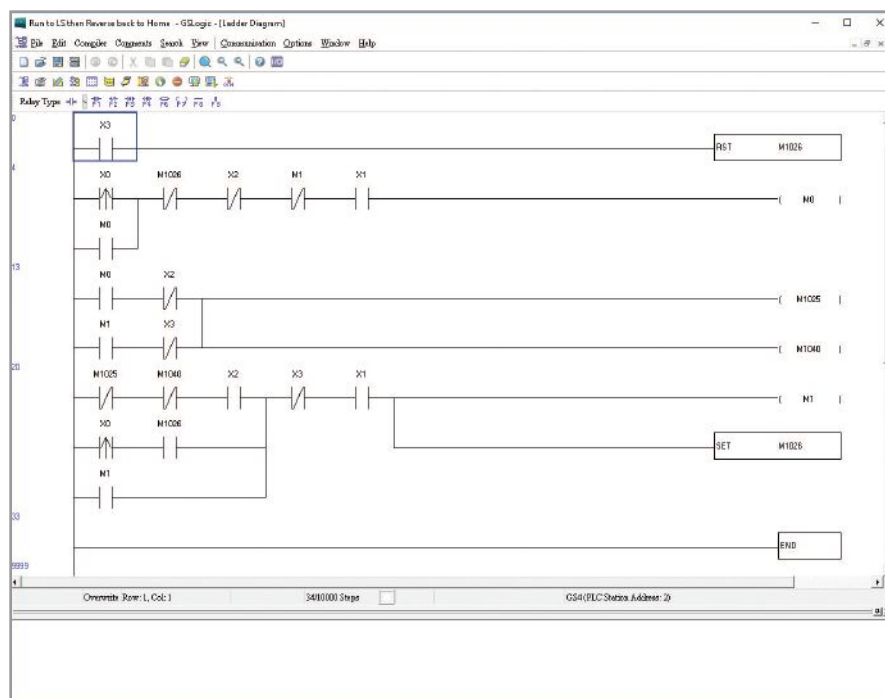

Figure 2. Many AC VFDs have built-in PLC logic operation with simple programming interfaces that will be familiar to those with PLC programming experience. They also include other features such as PID control and Ethernet communications.

more convenient, and if more than one VFD is installed and controlled by a separate PLC, they are easily networked together. The ability for human-machine interface and supervisory control and data acquisition systems to monitor and control many VFDs connected on a manufacturing plant network is attractive to end users and OEMs alike, providing advanced operation and supporting proactive maintenance to avoid breakdowns.

PID control. For applications involving analog process control—such as the flow of a pump or fan—it is usually necessary to implement closed-loop PID control. This can be accomplished in a PLC. However, for many applications, the VFD can more effectively handle this function locally, while offering an easy interface to tune the loop, saving substantial time during the machine startup.

Most machines require some sort of control even if they are not operating an analog process. Originally, this required hardwired relay logic, which was eventually superseded by PLCs to a great extent. For many smaller applications—especially in the OEM or hobbyist realm—a PLC integrated into the VFD has adequate I/O to control everything needed and represents a win-win on cost, design/programming labor, and panel space (figure 2).

Micro VFD considerations

There are few technical downsides to using a micro VFD in simple, lower-cost applications. A good rule to follow is if you are certain that you will never need to adjust the speed of a motor, then do not purchase a VFD. But if there is even a slight chance that the motor speed may need adjustment, then a newer, low-cost, high-feature VFD should be a top consideration.

Concerns might be the added size of a VFD compared to a contactor or starter, but some current models are palm size and consume about the same space as a motor contactor and overload combo (figure 3). These micro VFDs have a built-in PLC, PID control, sensorless vector control, advanced network support, and I/O expansion—at a cost comparable to that of a motor contactor and overload combo—but with added benefits and reduced costs in other areas. They are available consolidated into a NEMA 4X package suitable for washdown areas (figure 4).

OEM machines often use a small PLC controlling an across-the-line motor starter assembly. Traditional designs typically require three-phase power, but

many end users want this machine to work in single-phase facilities. Instead of creating two separate designs, the OEM could replace the PLC and motor starter assembly with one newer VFD that can accept a single-phase power input. With this solution, the OEM solves the problem; costs are reduced; and there are fewer components and more potential customers.

Even today’s hobbyists have a need for micro VFDs. For example, many individuals buy a second-hand industrial lathe or grinder, which most likely requires three-phase power for one or more motors. Even if the motor(s) is replaced, the user should replace it with another three-phase motor, so the speed may be varied. If the final use of the machine is a residential garage or personal workshop, it is unlikely the user will have three-phase power available. Although the output of the VFD cannot be used to power the entire machine, some minor wiring changes can be incorporated, allowing the VFD to control the three-phase motor with a single-phase input.

Although basic small VFDs still exist, there are several compelling reasons for OEMs, hobbyists, and other end users to use newer and extremely capable micro VFDs. In many cases, these micro VFDs have benefited from the trickle-down effect. ■

All figures courtesy of AutomationDirect



Figure 3. Micro VFDs can fit into about the same space as a traditional contactor/overload combo, yet provide many benefits and can even reduce costs in many areas.



Figure 4. A modern micro VFD with advanced features and a NEMA 4X rating can provide all the necessary logic, process, and motor control for a compact application, and often an entire control enclosure can be eliminated.

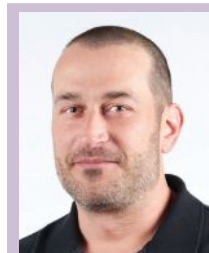

ABOUT THE AUTHOR

Kevin Kakascik is a technical marketing engineer at AutomationDirect. Over his 20-year career he has held controls engineering positions for machine OEMs, entertainment industry systems integrators, and material handling systems integrators. Kakascik has worked at AutomationDirect since 2013 in technical and marketing roles. He holds a bachelor's degree in computer science and engineering technology and an associate's degree in electrical engineering technology.

The Smart Manufacturing Revolution is Happening Now... Will You Be Left Behind?

Connect with hundreds of attendees and experts and get inspired and educated about emerging technologies that upskill the workforce, improve quality and advance your manufacturing operations.



SMART MANUFACTURING EXPERIENCE

June 7-9, 2022

David L. Lawrence Convention Center
Pittsburgh, PA

smartmanufacturingexperience.com

888.457.0763



ATTEND | EXHIBIT | SPONSOR

Using Flowmeters to Improve Boiler Efficiency

By Scott A. Rouse

Know your options when selecting the appropriate flowmeter technology to measure natural gas, water, and steam in power generation.

In many chemical plants, the electricity the plant uses is derived from a natural gas power plant or a cogeneration plant burning waste gas streams. In large boilers (figure 1), power plants bring together air and fuel (natural gas, waste gas, oil, or coal) for combustion, which creates heat. The heat boils the water, creating steam. The steam runs through a turbine, which causes the turbine to spin, thus generating electricity.

Measuring the flow energy—flows of fuel that cost money—in these boiler applications is critical for improving energy efficiency, identifying waste, and minimizing the greenhouse gases (GHG) going into the atmosphere. Only with accurate flow measurement can users make informed decisions to improve energy efficiency.

How do users decide which flowmeter technology is best to measure the gas, water, and steam for boiler applications? Choosing the right flowmeters

depends on the fluid being measured. When discussing boiler efficiency improvements, three primary applications are involved:

1. Accurate inlet air and fuel (natural gas, waste gas, oil, or coal) measurement for efficient combustion.
2. Inlet feedwater measurement to

determine steam production efficiency and to identify waste.

3. Measurement of outlet steam production.

Optimize fuel-to-air ratio

Power generation requires inlet air and fuel for combustion. Engineers must measure the air and gas ratio accurately

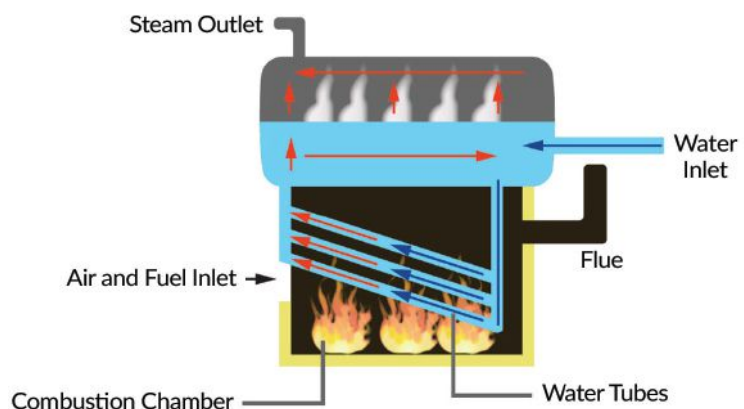

Figure 1. In typical boilers, air and fuel are combined for combustion, which creates heat to boil the water, creating steam. The steam causes a turbine to spin, generating electricity.

for efficient combustion in the boilers. Too much gas is wasteful, dangerous, and costly; too little creates insufficient flame to boil the water efficiently.

Orifice and turbine meters. Traditionally, monitoring fuel gas to the boiler units is accomplished with an orifice or turbine meter. However, these are not the best measuring devices for this application because they are subject to failure and require frequent skilled maintenance to provide an accurate and reliable measurement. Constrained piping conditions also can give engineers headaches. For example, an orifice meter requires 10 to 50 diameters of upstream piping to eliminate the effect of flow disturbances. Because long straight pipe runs are hard to find, most flow measurement systems are affected adversely by varying flow profiles within the pipe.

The biggest cause for concern is that orifice and turbine meters measure volumetric flow. Additional pressure, temperature, and differential pressure sensors, as well as a flow computer, are required to calculate or infer mass flow (figure 2). This not only degrades the flow measurement accuracy, but the installation and maintenance costs with this type of compensated measurement increase the cost of ownership.

Thermal mass flowmeters. In contrast, thermal mass flowmeters are suitable for direct mass flow measurement of gases, not volumetric flow. Because thermal mass flowmeters count the gas molecules, they are immune to changes in inlet temperature and pressure, and measure mass flow directly without compensation. In inlet air and gas flow boiler applications, thermal flowmeters perform well because the optimal fuel-to-air ratio for efficient combustion in boilers is calculated on a mass basis, not a volumetric one (figure 3).

In a thermal flowmeter's simplest working configuration, fluid flows past a heated thermal sensor and a temperature sensor. As the fluid's molecules flow past the heated thermal sensor, heat is lost to the flowing fluid. The

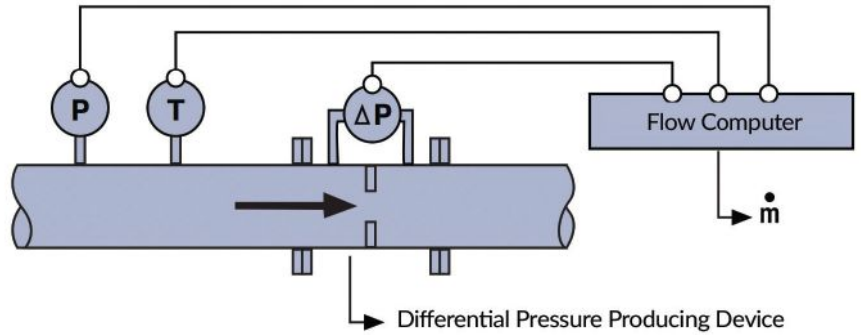

Figure 2. Typical differential pressure flowmeter with additional pressure, temperature, and differential sensors to infer mass flow.

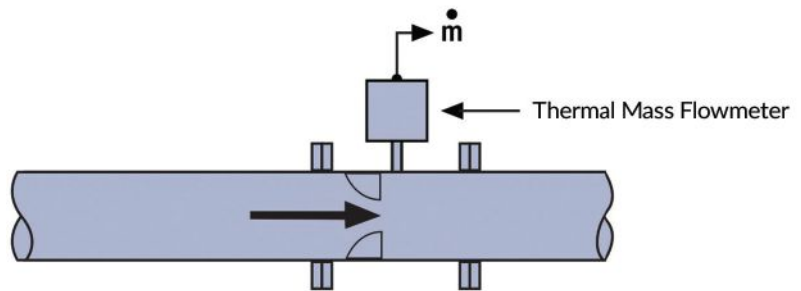

Figure 3. Direct mass flow measurement using thermal mass flowmeters.

thermal sensor cools down, while the temperature sensor continues to measure the flowing fluid's relatively constant temperature. The amount of heat loss depends on the fluid's thermal properties and its flow rate. By measuring the temperature difference between the thermal and temperature sensors, the flow rate can be determined.

New developments in four-sensor thermal technology, coupled with stable "dry sense" sensor technology as well as advanced thermodynamic modeling algorithms, enable some thermal flowmeters to attain ±0.5 percent reading accuracy, rivaling Coriolis flowmeter

accuracy at less cost. Onboard software apps also enable gas-mixing capability, in situ validation, and dial-a-pipe.

Measure inlet feedwater accurately

Water is also an expensive flow energy and limited resource. In boiler applications, it is important to measure the inlet feedwater flow to the boiler accurately, because users need to measure the efficiency at which the boiler turns this feedwater into steam (figure 1).

Clamp-on ultrasonic flowmeters.

Although users could measure inlet water with a volumetric vortex flowmeter, clamp-on ultrasonic flowmeters

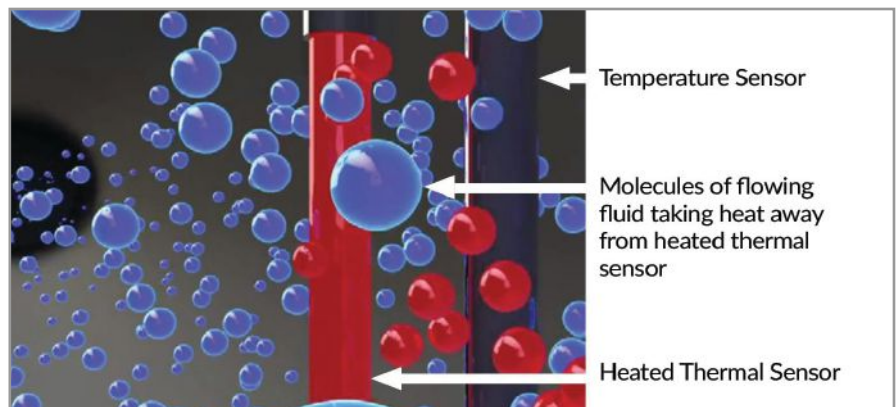

are ideal for water flow applications due to their ease of use and application flexibility. They achieve high accuracy at low and high flows, save time with no pipe cutting or process shutdown, and are not affected by external noise. Advances in ultrasonic technology now have onboard software and apps that make the meter easy to install, providing a visual signal that it has been done correctly.

Optimize steam production

The boiler's steam must be measured accurately to determine whether the boiler is producing the expected amount of steam or needs to be tuned for increased efficiency (figure 1). Traditionally, steam flow has been measured with a differential pressure device, typically an orifice plate.

However, such devices are inherently volumetric flow measurements. Changes in pressure and temperature will change

the steam's mass flow rate. Even a "small" change of 10 percent in steam pressure will result in a 10 percent error in noncompensated mass flow. This means that, in a typical differential pressure measurement installation, the volumetric flow rate must be compensated by measuring temperature and pressure. These three measurements (ΔP , T, and P) are integrated with a flow computer to calculate mass flow.

Insertion multivariable vortex flowmeters. Insertion multivariable vortex flowmeters measure steam output production from boilers more accurately. One insertion vortex flowmeter with one process connection measures mass flow rate, temperature, pressure, volumetric flow rate, and fluid density

simultaneously. Saturated steam's density varies with either temperature or pressure, while superheated steam varies with temperature and pressure, so multivariable vortex flowmeters ensure the flowmeter's density calculations are correct, and therefore, the mass steam flow measurements are correct. ■

All images courtesy of Sierra Instruments

ABOUT THE AUTHOR

Scott A. Rouse (s_rouse@sierrainstruments.com) is vice president of product management at Sierra Instruments.

Case Study: Thermal Flowmeters Improve Boiler Efficiency at a Chemical Plant in China

Purified terephthalic acid (PTA) is the precursor to polyethylene terephthalate (PET), the ubiquitous material used worldwide in plastic bottles, textiles, and elsewhere. A PTA chemical plant in China generates steam and electricity from its on-site power plant using coal as a fuel. It also has a wastewater treatment station that produces methane, which was flared off. Both processes are major GHG emitters.

New government regulations required the company to reduce its CO₂ emissions. The plant decided to modify its four boilers to burn both coal and the previously flared-off waste gas (methane), for a savings of approximately \$0.5 million in coal each year. Working with a single-source supplier, engineers reworked the boilers' designs and installed industrial insertion thermal flowmeters to measure its combustion air and waste gas fuel.

One thermal flowmeter measures the waste gas flow, while the other four thermal flowmeters provide submetering of this gas stream to each boiler. Another four meters measure preheated (200°C, 392°F) combustion air to each boiler, allowing the boiler control system to optimize the fuel-to-air ratio. The flowmeters provided both precision flow data for complying with government regulations and helped the company reduce waste while increasing efficiency.

Other potential metering applications are under review, including:

- Feedwater to the boilers using clamp-on ultrasonic flow: Because this is a preexisting feed piping system, a clamp-on ultrasonic meter is a flexible solution.
- Steam flow measurement: Measurement of steam flow delivered from the boilers to the turbine generator and submetering to the other plant processes.

ASSURED AUTOMATION

We Make Valve Automation Easy!
Build it, See it, Price it, Order it.

Point and click or tap to specify valve type, end connections, actuator, and accessories. Model number, price, description, and photo all update **instantly!**

Online Valve Configurators
Quickly & Easily Specify a Complete Automated Valve Assembly on Your PC, Tablet, or Phone

Build and Buy **YOUR** Valve Here

Wherever you see this image

Try one today at:
assuredautomation.com

#AutomationProDay Winners

Everyone was a winner on 28 April 1945, which was the day The Instrumentation Society of America got started. In honor of that anniversary, ISA this year christened April 28th as Automation Pro Day. Its social media outreach gathered pictures and stories and congratulated those professionals (and students) for making the world a better place through automation.

Felipe Sabino Costa submitted a picture “doing a cybersecurity training at the U.S. Department of Homeland Security facility to better protect our industrial control systems. #cybersecurity #training.”



Ryan Kershaw toasted the job that (among other things) proves that you can wear dressy clothes under Nomex coveralls; needs you to constantly learn just to keep up; dedicates a good portion of your phone photo storage to cool sites, random electrical and process equipment, parts of stuff to be identified later, and wiring setups; and usually means a lengthy explanation whenever you are asked what you do for a living.

Valentina Freire said, “What a joy to have a day only for industrial automation professionals! Congratulations to these thousands that I know and cherish so much!”

Winners of the social media contest for their submissions were:

- Srinath Krishnamoorthi, Professional
- Ryan Kershaw, Professional
- Prabhu Soundarrajan, Professional
- Ritam Mondal, Student

Visit ISA’s Facebook, Twitter, LinkedIn, Instagram, or Pinterest accounts to see all the stories and pictures. ■

In Memoriam: Bridget Fitzpatrick

Bridget Ann Fitzpatrick, ISA Fellow and process automation technical expert, died suddenly last month while traveling for work. She was 57.

Fitzpatrick was a highly knowledgeable professional with deep expertise in control and automation. She had a BS in chemical engineering from MIT, a graduate degree in chemical engineering from Michigan State, and an MBA in technology management from the University of Phoenix. She worked most recently for Wood, a global consulting and engineering firm.

Fitzpatrick was an active and enthusiastic ISA volunteer who was named an ISA Fellow in June 2016 for “innovative improvement of alarm management and human machine interface [HMI] design practices.” She was a member of the ISA Standards and Practices Board, as well as managing director of the ISA18, Instrument Signals and Alarms standards committee.

In 2010 she received ISA’s Standard and Practices Department Award (ISA-18.2) in recognition of her outstanding contributions as a technical editor in the development of ANSI/ISA-18.2-2009, *Management of Alarm Systems for the Process Industries*, and for pioneering

work in developing the first ISA standard on alarm management.

Fitzpatrick served the wider automation community as a member of the ISA84, ISA101, ISA105, ISA106, and ISA112 standards committees, and as a member of the board of directors for UniversalAutomation.org.

She also served as a U.S. expert to an International Electrotechnical Commission committee developing an architecture for distributed industrial automation systems.

Fitzpatrick was born in Portland, Maine on 27 December 1964 during an ice storm, the eighth child (sixth surviving) of Ada Fraser and James Fitzpatrick. As her obituary said, “she entered the world determined. Her determination, kindness, and brilliance were always a part of who she was. . . . Always at the back of her mind was a desire to solve big problems and ‘save the world.’” Donations in memory of Bridget Fitzpatrick may be sent to the ISA scholarship fund (www.isa.org/donation). ■



Bridget Fitzpatrick (left) gives her ISA Fellow 2016 acceptance speech; shown with Peggie Koon, PhD, 2014 ISA President.

Meet Graham Nasby, ISA Standards Excellence Award Winner



ISA annually gives out a range of awards honoring its volunteers for the professional work they do. ISA Standards, of which there are

more than 150, reflect the work of more than 4,000 industry experts from around the world. The 2021 Standards Leader of the Year, announced earlier this year, is Graham Nasby, water SCADA & security specialist for the City of Guelph, Ontario, Canada. Here are some things he has been working on, and how he feels about his standards work with ISA.

Nasby seems to have come naturally to his current job, having started at six years old with a succession of summer jobs rewiring boats at a local marina. This led to a lifelong interest in electrical systems and to obtaining a degree in electrical engineering and automatic control systems at the University of Guelph. Nasby's career took him into a range of consulting and manufacturing jobs in several industries: software development, structural engineering, semiconductor manufacturing, ready-mix concrete, pharmaceutical manufacturing, construction, and municipal water/wastewater.

Nasby earned his professional engineer (PE) license in 2010, received ISA's certified automation professional (CAP)

certification in 2012, and obtained his functional safety engineer designation in 2015. Since then, he has worked for the City of Guelph managing a team of specialists who look after the supervisory control and data acquisition (SCADA) system for the city's drinking water utility.

Nasby says he "cannot underscore enough the positive impact that ISA standards work has had on my career."

In search of useful best practices

"It was back in 2010 that I first got involved with a standards committee," Nasby says. "At the time, I was designing automatic control systems for high-purity water systems in the pharmaceutical industry. I was having a hard time finding useful best practices on how to design both the control system and its process alarms. Seeing an article in *InTech* about an 'alarm management committee,' I contacted the article's author [Nick Sands, now an ISA Fellow] and asked if I could get involved. Through the ISA18 committee, I was able to work with world-renowned experts in alarm management, as well as contribute back to the committee by sharing my own experiences. The committee also gave me an opportunity to develop my technical skills, and get experience with technical leadership, consensus building, and communication skills."

Fast forward to the present, and Nasby is now involved with multiple

consensus-based technical standards committees within both ISA and other organizations. These include the CSA P125 OT Functional Safety & Security Committee; the IEC TC65/TC65A Industrial Process Measurement, Control, and Automation committees; AWWA Automation committee; and ISA committees such as ISA18 Alarm Management, ISA99 Cybersecurity, ISA101 HMI Design, ISA105 Commissioning, and ISA112 SCADA Systems.

To become an expert in a field, seek out the best-of-the-best.

"It is primarily from my involvement with standards committees and the resulting relationships with other experts that has enabled me to build my career," Nasby adds. "I learned very early that one must always be learning, and, for me, standards-committee involvement is a big part of that. My participation in ISA standards committees has also given me great opportunities to practice my communication, writing, consensus-building, and leadership skills."

Nasby adds: "One of the major takeaways I have learned from being involved with ISA standards, is that if you want to become an expert in a field, you need to seek out the best-of-the-best for that field and find a way to work with them. Don't restrict yourself to just learning from people at your own company or from a specific geographic area. Being involved with consensus-based technical standards work, such as with the ISA, has enabled me to build my technical career."

Learn more about Nasby's role as co-chair of the ISA112 SCADA Systems standards committee and why the ISA 112 standard is important in a related post on the ISA Interchange blog (<https://blog.isa.org>). ■ -By Renee Bassett

ISA42, Nomenclature for Instrument Tube Fittings RP to Be Updated

ISA42, Nomenclature for Instrument Tube Fittings, is being reactivated to update a 2001 ISA recommended practice of the same name. The document defines nomenclature for tube fittings most commonly used in instrumentation, and is intended to apply to mechanical flared and flareless

tube fittings as commonly used in instrument tubing systems. The purpose is to aid in the proper specification and application of instrument tube fittings by standardizing nomenclature. Those who are interested in participating are asked to contact Charley Robinson, crobinson@isa.org. ■

Widely Used ISA Symbols Standard, ISA-5.1, Updated

The most widely used of all ISA standards, ISA-5.1, *Instrumentation Symbols and Identification*, has been published in a 2022 version that provides clarifications and corrections to the previous 2009 version.

Originally published as ISA Recommended Practice RP-5.1 in 1949, the document was revised and expanded to become an ISA and American National Standard in 1984, and then reaffirmed without change in 1992. Most of the identification letter and symbol meanings or definitions that were contained in ISA-RP5.1-1949 and ISA-5.1-1984 became and remain accepted practice across the worldwide process industry sectors.

In 2009, a major revision and update of the standard was completed in which the symbology and identification systems as described accommodated various advances in technology and reflected the collective industrial experience gained. That 2009 revision involved a detailed review by a large, multi-industry group of practitioners in the field of instrumentation and control, with an emphasis on the use of identification and symbol systems as a means of communicating the intent of measurement and control systems to all that need such information.

The 2022 revision of ISA-5.1 is intended to provide usage clarifications and to correct typographical and technical errors that have been uncovered over the years since the 2009 version. As such, this 2022 revision will serve as a basis on which the ISA5 standards committee can begin a more regular maintenance/revision cycle for this widely used international standard.

To that end, a new working group is now forming to begin work on the next revision of ISA-5.1. The overriding goal will be to continue strengthening the role of the standard as a communication tool in all industries that depend on measurement, control, and automation systems to operate and safeguard their manufacturing processes, machines, and other equipment. This standard and future versions will build on that foundation to serve the global process industry sectors.

All who are interested in actively participating in the new working group to begin the next revision of ISA-5.1 are asked to email Charley Robinson, ISA Standards, crobinson@isa.org. Access ISA-5.1-2022 at www.isa.org/findstandards. ■

This update was provided by Jim Federlein, retired PE and principal of Federlein & Associates, Inc. He is an ISA Life Member and a director on the ISA Standards & Practices Board. He is chair of the ISA5.1 working group and of ISA105, Commissioning, Loop Checks, and Factory & Site Acceptance/Integration Tests for Industrial Automation Systems. Federlein also serves on IEC SC65E WG3, Commissioning.

ISA & IEC In-Person Standards Meetings Reinstated

ISA95, Enterprise-Control System Integration, will hold the first face-to-face ISA standards meeting since 2019 on 9–10 June in conjunction with the ARC Forum in Orlando. For information on the event, visit <https://www.arcweb.com/events/arc-industry-forum-orlando>. For information on ISA95, contact crobinson@isa.org.

The Geneva-based International Electrotechnical Commission (IEC) will hold its 2022 general meeting 31 October – 4 November in San Francisco, hosted by the American National Standards Institute (ANSI). The general meeting brings together IEC delegates from across the globe for meetings and forums. Some 1,500 attendees are expected.

The primary IEC technical committee with which ISA standards committees interact, IEC TC 65 – Industrial-Process Measurement, Control and Automation, will not hold meetings in San Francisco. However, a committee in which several ISA standards leaders are active will meet. For information on the IEC event, visit www.iec.ch. ■

ProComSol
Process Communications Solutions

Convert your mobile device into a full featured HART communicator.
A modern replacement for expensive hand-helds

Diagram illustrating the conversion of mobile devices into HART communicators. It shows a central industrial control panel connected to various mobile devices (iPhone, Android, Windows) via wireless signals. The devices are labeled 'WirelessHART' and 'HART'. A cloud icon labeled 'DEVICE CONFIGURATIONS' is connected to the devices, and a label 'Cloud features!' is below it.

ProComSol, Ltd is a leader in the design and manufacture of advanced, cost-effective, and reliable HART communication products for the Process Control marketplace.

+1 216 221 1550 sales@procomsol.com

procomsol.com

Hazardous area options available for Windows and Android!

ISA Launches Indian Power Infrastructure Virtual Conference

Digital transformation of power infrastructure is rapidly making industry operations more efficient, manageable, and sustainable around the world. Distributed power is no longer a future concept, but a day-to-day reality, and digital management of this new architecture accelerates this adoption.

ISA's latest Digital Transformation Virtual Conference will have fresh content focused on cybersecurity and digital transformation topics related to the power infrastructure of India.

This virtual event will take place on 21 June 2022. An in-person component of this event will take place in Faridabad, Haryana, India, and session content will be provided in part by the government of India Ministry of Power.

Driven by smart substations, power generation has become increasingly sustainable, ushering in an energy revolution within India. The conference will address increased vulnerability of critical infrastructure. For more information, visit <https://programs.isa.org/dt-india>. ■

New CAPs and CCSTs

The following individuals have recently passed either ISA's Certified Automation Professional (CAP) exam, or one of the three levels of the Certified Control Systems Technician (CCST) exam. For more information about either program, visit www.isa.org/training-and-certification/isa-certification.

Certified Control System Technicians Level 1

- Joseph Barrett, Alyeska Pipeline Service Company, U.S.
- Derek Belkofer, U.S.
- Gary Clarke, South Florida Water Management District, U.S.
- Robert Allen Houtman, Jr., Kalsec Inc., U.S.
- William Joseph MacClain, Hollyfrontier Tulsa Refining LLC, U.S.
- Mitchell Mann, Alyeska Pipeline Service Company, U.S.
- Sean W. Marsh, U.S.
- Brandon Mastey, Xcel Energy – Sherco, U.S.
- Gunnar D. McConnell, Xcel Energy, U.S.
- Seth Milne, Bureau of Land Management, U.S.
- Sami A. Motairi, U.S.
- Ronney Neely, Ann Arbor Wastewater Treatment Plant, U.S.
- Juan Negrete, Akorn Pharmaceuticals, U.S.
- Enrique Ochoa, Flint Hills Resources, U.S.
- Desmond Paxton, U.S.
- Miguel A. Renteria, U.S.
- Jesse Shepherd, Alyeska Pipeline Service Company, U.S.
- Jesse Sherman, Associated Electric Cooperative Inc., U.S.
- Michael Thorn, U.S.
- Christopher L. Thrower, U.S.
- Julian Trott, Bermuda
- Branden Williams, Messer, U.S.

Level 2

- Christopher P. Criblez, U.S.
- Paul Kaczorowski, MillerCoors, U.S.
- Drew Lopez, Metropolitan Water District of Southern California, U.S.
- Antonio Mar, U.S.
- Zulamin Masahod, Emirates Global Aluminium – Alumina Refinery, Philippines
- Seth Milne, Bureau of Land Management, U.S.

- Cole Neufeld, SaskPower, Canada
- Zach A. Otto, U.S.
- Devin Payne, U.S.
- Joseph Storer, American Refining Group, U.S.
- Gary Wheaton, Pacific Business Partners, U.S.
- Seth Young, MillerCoors, U.S.

Level 3

- Harold D. Daniels, U.S.
- Gregory F. Gagnon, Advanced Control Systems, U.S.

Certified Automation Professionals

- Ote Amuta, Schneider Electric System Limited, Nigeria
- Gregory M. Castillo Arrayago, Kas T Jo Consulting, Canada
- Khairul Redwan Bin Muhammad, Hexagon PPM, Malaysia
- Ibnu Munzir, KIPIC, Kuwait
- Onome Omene, Bendel Automation and Controls Inc., Canada
- Scott E. Owen, MWRDGC, U.S.
- Alaa Hussein Owis Mohamed, Egypt
- Hernan R. Patino, ECOPETROL S.A., Colombia
- Panisa Polpattana, U.S.
- Yusuf Pribadi, Indonesia
- Luis Guillermo Rodriguez Alvarez, Instrumentos y Controles S.A., Colombia
- Sankarsan Sahoo, Republic of Korea
- David Sanchez, Ecuador
- Jesse Sherman, Associated Electric Cooperative Inc, U.S.
- Anil Manohar Shinde, Canada
- Wei Hong Tai, Excel Marco Industrial Systems Pte. Ltd., Singapore
- Wee Siam Tan, Singapore
- Chengyu Wang, U.S.
- Tyler Watson, BSI Engineering, U.S.
- Joshua Welch, U.S.

InTech advertisers are pleased to provide additional information about their products and services. To obtain further information, please contact the advertiser using the contact information contained in their ads or the Web address shown here.

Advertiser	Page #
Assured Automation www.assuredautomation.com	30
AutomationDirect www.automationdirect.com	Cover 2, insert at 18
Endress + Hauser www.us.endress.com	7
Inductive Automation www.inductiveautomation.com	Bellyband, 23
ISA Membership www.isa.org/membership	Cover tip
Maverick Technologies, a Rockwell Automation Company www.mavtechglobal.com	Cover 4
MOXA www.moxa.com	5
Opto 22 www.opto22.com	3
ProComSol, Ltd www.procomsol.com	33
Real Time Automation https://www.rtautomation.com	10
SME www.smartmanufacturingexperience.com	27
Tadiran https://tadiranbat.com	9

Print + Online = Success



Download the ISA InTech/Automation.com Media Planner:

<https://tinyurl.com/InTechAcom-2022mediakit>

Optimize Energy Efficiency and Sustainability

Energy conservation is being pushed to the top of the priority list, driven by world events, rising energy prices, and supply chain issues. Pursuing energy conservation is compatible with achieving climate improvement and sustainability goals to which automation and control professionals can make even more meaningful contributions.

Manufacturing is a significant energy user worldwide, making conservation efforts a priority. For example, the U.S. Energy Information Administration (EIA) reported in 2020 that the industrial sector accounted for 33 percent of total U.S. energy consumption. Energy is generally a hidden cost that is part of factory overhead and not tracked as part of the bill of materials for production. Out of sight, out of mind. In addition to lowering consumption, the return-on-investment (ROI) analysis for energy saving expenditures should factor into increasing company competitiveness.

Awareness and engineering

Automation professionals can achieve more efficient energy use starting with awareness, followed by engineering to save energy. The same engineering logic used to control the production process applies to energy management. Using energy input and output and real-time measurements, the efficiency of production processes can be calculated and optimized.

An important first step is measuring and tracking where, when, and how much energy is being consumed. Before making investments in energy and power monitoring devices, automation professionals can use existing data in supervisory control and data acquisition, human-machine interfaces, and historians. They contain a wealth of information to develop meaningful profiles of energy consumption and deviation without adding more hardware. For example, by tracking motor run times and using the nameplate power consumption information, power consumption can be calculated to track approximated energy use without adding more hardware. Add to this alarm limits to detect unusual run times, and unusual start/stop cycles can be used to infer problems that are wasting energy.

Using sound application engineering to improve efficiency can reduce energy. For example, multiple boilers serving a process plant typically each have different nonlinear efficiency characteristics-based

load and output levels. Accurately measuring demand and using the efficiency curves can help select part loading of the boilers to achieve the most efficient energy use while serving the needs of the process. This can be done easily in existing systems and does not take artificial intelligence or highly elaborate algorithms to accomplish.

Practical solutions

Ongoing monitoring provides the data to create profiles and reports that are a foundation for reporting energy data and identifying deviations and areas for improvement. Analyzing patterns of this data analysis permits plants to make better decisions about controlling energy costs and making investments.

Fundamental monitoring and control methods are the first step, and later, other investments can be made after analyzing the data to develop ROI for more sophisticated energy savings investments. These might include minimizing peak demand by applying an electrical load-management system to monitor and control electrical consumption of selected equipment, automatically turning off air supply lines when product is not being produced, and using compressed air control systems to optimize operations.

When data is not tracked and related to production output, it can appear that the initial energy consumption investments are not paying off. Sustaining an effective energy program requires ongoing data collection and analysis. Several methods can be useful:

- continue to reinforce energy as a priority in operational decision making
- communicate program successes as they occur
- extend power- and energy-monitoring solutions to support continuous-improvement efforts
- build in alarm advisories for energy key performance indicators.

Energy conservation is essentially another type of control application engineering task to achieve production requirements efficiently and reliably at the lowest energy consumption. ■



By Bill Lydon

Lydon (blydon@isa.org) is an *InTech* contributing editor with more than 25 years of industry experience. He regularly provides news reports, observations, and insights here and on Automation.com.

Recent energy price escalation, supply chain issues, and world events are putting renewed emphasis on more efficient energy use.

WE'VE GOT YOU COVERED

- Process Automation
- DCS Modernization
- Systems Integration
- Startup & Commissioning
- Field Service
- 24/7/365 Support

Let's Talk About Your Control System Performance.

MAVERICK[™]
TECHNOLOGIES

A Rockwell Automation Company

mavtechglobal.com

info@mavtechglobal.com 888.917.9109



READ THE
CASE STUDY

**GOOSE
DUG UP!**

mavtechglobal.com/goose-intech



Ignition! 8.1

by inductive automation

Built For The Plant Floor

Build Mobile-Responsive HTML5 Applications
That Run Natively on Any Screen





! ! 8.1

Try Ignition 8.1 For Free Today at
www.inductiveautomation.com

Built For Everyone



Unlimited Licensing Model

Add unlimited clients, screens, tags, connections & devices.



Cross-Platform Compatibility

Ignition works with any major operating system, even iOS and Android.



Instant Installs and Updates

Install on a server in just 3 minutes, push updates to clients everywhere, instantly.

InTech[®]

OFFICIAL PUBLICATION OF THE INTERNATIONAL SOCIETY OF AUTOMATION

JUNE 2022



isa.org/membership

ISA MEMBERS - CREATING A BETTER WORLD THROUGH AUTOMATION



A community designed for
you to connect, engage,
and collaborate

There is Value in Membership



ISA is a member-focused association, centered on offering you the community and tools needed to shape the future of automation. We focus on values like excellence, integrity, diversity, collaboration, and professionalism. ISA is not just an association, we are a community, built for professionals like you.



ISA Connect

Engage in technical discussions - both online and live - with automation professionals like yourself all around the world.



Career Center

Search job boards, build your resume, or get help career planning – all the tools you need to advance your career in automation.



Standards

Access over 150 standards that reflect the expertise of industry leaders from around the world!



Networking

Enhance your professional network by connecting with members in your local community or in your technical specialty.



Education and Training

Receive discounts on training courses, event registrations, books, and professional credentials.

Visit [ISA.org/membership](https://www.isa.org/membership) to learn more!





When every dollar counts...



...count on

AutomationDirect!



Over 35,000 quality industrial control products at great everyday prices are available on our webstore 24/7/365, and each one comes with the customer service you deserve.

AUTOMATIONDIRECT.com
 www.AutomationDirect.com 1-800-633-0405
The #1 Value in Automation



AutomationDirect: much more than just a

AutomationDirect is a non-traditional industrial controls company. We bring new ideas from the consumer world to serve your automation needs. We provide quality products fast for much less than traditional suppliers, and we take every step of the way. See below . . .



You need quality products at great prices.

Our campus is located about 45 minutes north of Atlanta, GA, USA. **We're all here** - our sales and technical support teams, purchasing, accounting, and of course our huge warehouses and speedy logistics team.

You want complete product information to make the right purchase decision.

Whether you're deciding on purchasing our products or learning our products after you buy, why jump through hoops or even pay for the information you need?

We have exhaustive documentation all freely available online, including overviews, technical specifications, manuals and 2D and 3D CAD drawings.

We have **over 1,200 videos online** to get you up to speed quickly. We even provide **FREE** online PLC training to anyone interested in learning about industrial controls.

<http://go2adc.com/videos>

<http://go2adc.com/training>



Proximity Sensors	AutomationDirect Price/Part Number	VS.	Price/Part Number
5 mm three-wire DC prox with pico Q/D	\$45.50 PD1-AP-1F		\$187.10 8710
8 mm three-wire DC prox with pico Q/D	\$17.50 AE1-AN-2F		\$187.20 8720
12 mm two-wire DC flush prox with 2 m cable	\$24.00 AM1-AO-2A		\$87.20 8720
18 mm flush AC prox with 2 m cable	\$34.50 VK1-AO-1B		\$187.20 8720

Q/D = quick disconnect

*All prices are U.S. published prices. AutomationDirect prices as of 11/17/2021. Allen-Bradley prices are taken as of 11/5/2020. Prices may vary by dealer. Many other part numbers are available from a...

For over 25 years, we've been offering a better value by running our direct business efficiently and passing it on to you. No complex pricing structures or penalty for sales. Everyday prices on everything from fuses to motors.

Programming software for controller products can be costly, so we help you out by offering **FREE downloadable software** for all our latest PLC families and C-more HMIs. No license or upgrade fees to deal with!

<http://go2adc.com/why>

You don't want to wait for your order.

We have fast shipping, and it's **FREE** if your order is over \$49.*

At AutomationDirect, we strive to have what you need, when you need it. We've invested heavily into infrastructure, inventory, and automation so that we can continue to provide you with quality products, at great prices, extremely fast!

*Order over \$49, and get free shipping with delivery in 2 business days in the U.S. (Certain delivery time or shipping cost exceptions may apply. Conditions online for complete details. <http://go2adc.com/terms>)

You insist on getting better service and you want it FREE.

Our technical support team provides superior assistance and has consistently received high ratings from satisfied customers. And it won't cost you a cent!

Before, during, and after any sale, contact us with questions and we're glad to help, <http://go2adc.com/support>



“.com”

Company using the best products. We deliver quality and support you

Best prices.

Allen-Bradley Price/Part Number

83.14	
-D1NP5-P3	
101.29	
-D3NN8-P3	
39.68	
-D3NE12-A2	
29.04	
-A5N18-A2	

Learn more from www.wemerelectric.com and our sales team. We'll help you find the best vendors.

Save on industrial controls by spreading the savings on to smaller orders, just low prices.



Customer Service

When you need technical support and warehouse support, you'll get quality

response (or less) within 24 hours, usually; see Terms and Conditions



This “.com” is powered by “.awesomepeople”!



Our primary focus has always been customer service — practical products, great prices, fast delivery, and helpful assistance. But the intangible value of customer service is something that cannot be faked, automated or glossed over.

Our team members here at AutomationDirect.com approach every day with one goal in mind - serve the customer. If the answer to any decision is “Yes, this is good for our customers”, then we do it, whether personally or via self-serve features on our site.



Easy access to account and order history, online returns

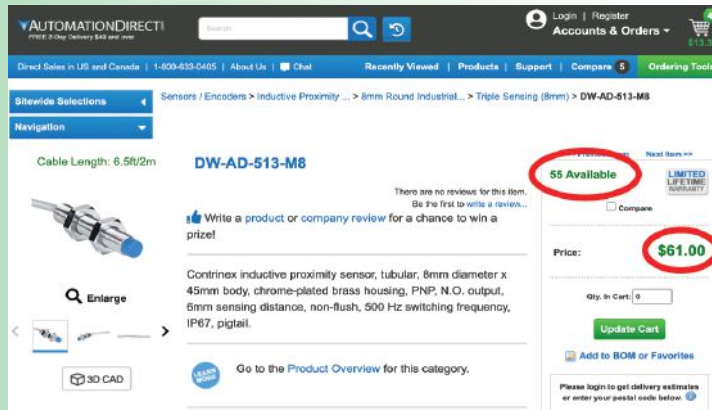

Upfront pricing and realtime stock availability



You want to be confident in our products and our commitment to you.

We stand behind our products and guarantee your satisfaction.

We want you to be pleased with every order. That's why we offer a 30-day money-back guarantee on almost every stock product we sell. (See Terms and Conditions online for exclusions.)



Check us out at: www.automationdirect.com

The best values in the world . . .

We've shopped around to bring you the most practical, reliable industrial control products at the best prices!!

Hayk in CLAREMONT, CA:

"Competitive prices on most of the selection. Easy to order on the web, no sales rep or middle man needed."

Jack in GILLSVILLE, GA::

"Great customer service, tech support, shipping and delivery. Using Automation Direct removes the need to carry a lot of inventory."

THandley in MIDLAND, TX:

"We have been using Automation Direct for close to 15 years if not more. They have never failed to deliver as promised. Whether its getting a small part sent to one of our job sites along the east coast or overnighting a VFD to our jobsite in Fresno or Oxnard California you can rest assured it will be there when they say it will be there. This has made me a repeat customer for life."

Todd in MEMPHIS, TN:

"I have been pleased with the service and products for several years. Have only had a couple occasions with a need to speak to customer service and it was always handled promptly and efficiently. The products available, delivery and service keeps me coming back."

Henry in LABELLE, FL:

"Over 12 years ago, installed a network of twelve DL06's communicating via H0-ECOM 100 modules throughout our plant, saving thousands of feet of wire previously needed for control wiring. It has allowed the operation and monitoring of pumps, conveyors, and other equipment from multiple locations. More recently, added more control stations using C-MORE touch panels, instead of physical switches and pilot lights. All this has resulted in tremendous savings, safety, ease of troubleshooting, and flexibility. Thank you AD for affordable products, great help with tech support, reasonably (and often free) software and good quality products."



A quality product line, with FREE
#1 rated technical support and quick shipping!

Call 1-800-633-0405 or visit us at:
www.AutomationDirect.com